



GLOBE AIRMOTORS B.V.

GLOBE Airmotors | Boerhaaveweg 9-11 | NL - 2408 AD Alphen a/d Rijn | Tel +31 172 426 608 | info@globe-benelux.nl

Brochure

GLOBE Vane Air Motor



globe-airmotors.com

About GLOBE Airmotors

GLOBE Airmotors is part of the GLOBE Group. The GLOBE Group was founded in 1986 and specializes in the developing, producing, advising and sales of air motors, gas boosters, high pressure test equipment and systems.

The focus of GLOBE Airmotors is mainly on the production and sales of the air motors. We offer a very wide program of different types of air motors. With a team of experts with lots of experience, we are able to help with all kinds of questions about air motors and everything related to high pressure. A big benefit is that we have our own production department. Because of this, we do not just exactly know what we sell, we can also provide customization for all our products.

GLOBE Airmotors has a high standard when it comes to the quality of our products. Pneumatic drives are often applied in explosive atmospheres. That is why it is possible to order most of our air motors, including the gearboxes and brakes, with ATEX certification. We are also ISO 9001: 2015 certified to guarantee our work processes and quality.



Contents

About GLOBE Airmotors	2
About the GLOBE Vane Airmotor	3
Working Principle	4
Controlling	5
Advantages	6
Motor selection & Ordering code	8
V1 Vane Air Motor	10
Dimensions, Performances & Spare Parts	11
V2 Vane Air Motor	13
Dimensions, Performances & Spare Parts	15
V4 Vane Air Motor	18
Dimensions, Performances & Spare Parts	19
V6 Vane Air Motor	22
Dimensions, Performances & Spare Parts	23
V8 Vane Air Motor	26
Dimensions, Performances & Spare Parts	27
V10 Vane Air Motor	30
Dimensions, Performances & Spare Parts	31
V12 Vane Air Motor	34
Dimensions, Performances & Spare Parts	35
Accessories	38
Gearboxes	40
Brakes	42
Controls	44
Air quality & Air line Components	46
Silencers	47

The GLOBE Vane Air Motors

The vane air motor is the most widely used design of air motor. They are available in a broad range of power and can operate in any position. Thanks to our unique and simple construction, this air motor is maintenance-friendly, easy to use and offers a long service life. Because of their design, these air motors are intrinsically safe, self-cooling and therefore very suitable for use in situations with explosion hazard and/or extreme conditions such as moisture and high temperatures. In addition, they are lighter and smaller than electric motors and when compared with piston air motor of similar power. Our vane air motors are delivered as standard in accordance with ATEX.

Our air motors have a power range from 0,50 kW up to 14 kW. The air motors can be supplied in combination with a gearbox for higher torques and lower speeds. Custom built solutions are possible due to our own design and production department. All standard motors are available from stock.

Advantages of a GLOBE Vane Air Motor

The GLOBE vane motors are compact and lightweight compared to equivalent electric and piston motors. Thanks to the unique and simple design, the GLOBE vane motors have less wear and tear. This ensures a longer life with less maintenance. The power and speed are easily adjusted by pressure and air flow. Our pneumatic motors can endure overload for a long amount of time and can even be blocked completely without damage to the motor.



Modular design

The vane motors can be expanded as desired with various accessories such as brakes, (control) valves and gearboxes.



Suitable for every operating condition

Our vane motors are safe to use in environments with high temperatures or humidity. Standard with ATEX Certification for extreme conditions in hazardous areas.



Robust

Our GLOBE vane air motors can be overloaded or blocked for a long time without damage.

Standard with ATEX Certification

The GLOBE vane air motors are delivered as standard with ATEX. Our ATEX certificates are according to the following (harmonized) standards:

EN-ISO80079-36:2016
EN-ISO80079-37:2016

The motors are marked with the following EX marking:

CE UK CA Ex II 2G Ex h IIC T4 Gb
II 2D Ex h IIIC T135°C Db
-20° ≤ Ta ≤ + 60°C

In which:

II	Equipment group II for use above ground
2G	Category 2G for use in Zone 1 or 2
2D	Category 2D for use in Zone 21 or 22
Ex h	Protection by constructional safety "c" Gas
IIC	group IIC
IIIC	Dust group IIIC
T4	Temperature class T4
T5	Temperature class T5
T100°C	Maximum surface temperature 100°C
T135°C	Maximum surface temperature 135°C
Gb	Equipment protection level Gb
Db	Equipment protection level Db
Ta	Ambient temperature range

Working Principle

No pins or springs

The GLOBE construction is based on the principle of roller bearings. In this construction, the vanes are held together by the outer ring (the motor body, shown as 1 in the figure below) and the inner ring (the ejection ring, shown as 2 in the figure below). Two ejection rings are placed centrally from the motor body on the front and back side of the rotor, keeping the vanes (3) in place.

The rotor (4) is placed in an eccentric position from the motor body. With the GLOBE construction, the vanes have circular tips so the ejection ring is kept perfectly in the center of the motor body. Because the contact between the vanes and the motor body is spread over an arc, there is almost no clearance and wear of the vanes is low, giving the vanes a much longer life.

The ejection ring ensures that the vanes are constantly in contact with the motor body to avoid air leakage and loss of power. This provides the motor of a high positive start, also when the motor hasn't been used for a long time. Breakdown of the motor hardly occurs due to the GLOBE construction. This results in a **long lifetime** and an improvement of the motors **reliability**.

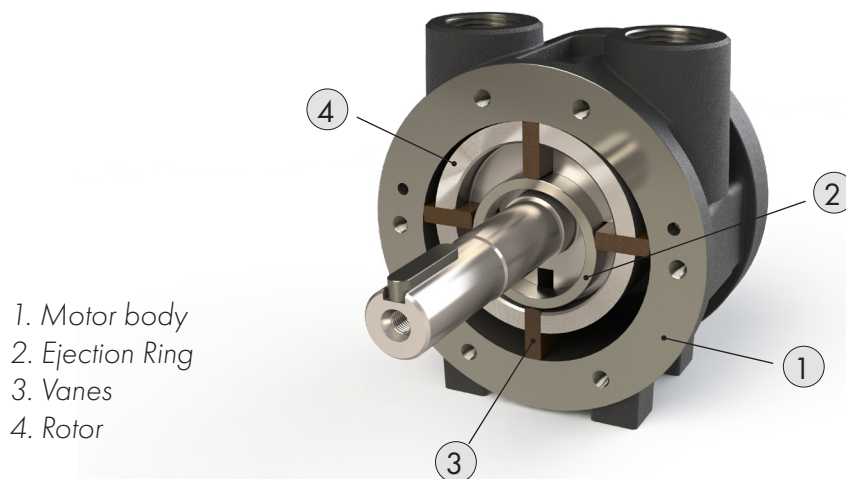

The GLOBE blade ejection system guarantees the blade position on start up, preventing free air flow from port to port and ensuring the motor produces its rated starting torque. The ejection ring design removes the requirement for pins or springs, the result is **low vane wear** and a **high motor reliability**.

Power and torque

The output power of a vane motor varies as a function of speed and torque. The relationship when the air supply is not externally regulated is shown in the graphs on the right.

A typical characteristic of vane air motors is the variable starting torque for a given input pressure; a result of the varying vane position at start up. This variation is different for every type of vane air motor. For applications with starting load, the minimum starting torque produced should be used in calculations. For lower speed operation with a high torque requirement, a large variety of gearboxes and combinations are available

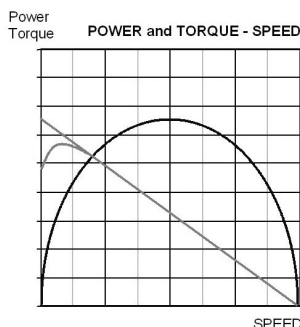

Controlling Speed, Torque and Power

The GLOBE vane air motors are easy to control and one of the toughest and versatile type of motors available. The performance is dependent on the inlet pressure. When the inlet pressure is constant, the torque/speed output of the GLOBE vane air motors will have a linear relation, as shown in the graphs below. By regulating the air supply, the output of the vane air motor can be altered. Regulating the air supply can be done with two methods: throttling and pressure regulation.

Throttling

The air flow is controlled by placing a flow control valve at the inlet port or the outlet port of the air motor. Throttling will reduce the maximum speed of the motor but will hardly affect the starting performance; the air pressure is unaffected at low flow conditions i.e. starting. Note the difference in the graph between throttling on the inlet port and outlet port.

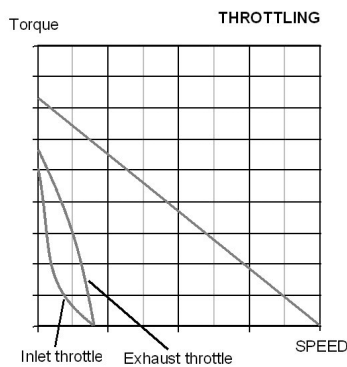

Pressure regulator

The speed and power can also be reduced by installing a pressure regulator on the incoming air supply. The pressure regulator reduces the air pressure to the motor. A pressure regulator must be fitted in the air supply line. By using a pressure regulator the torque on the output shaft will be affected, starting torque and/or power is best controlled with this method.

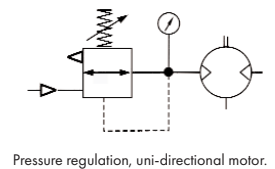
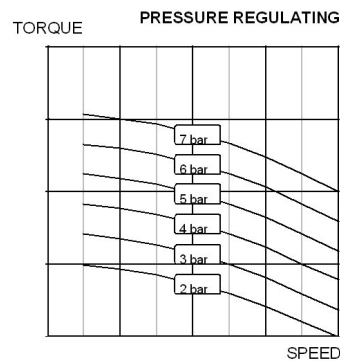

When both the speed and the torque are to be controlled the best configuration is to use a pressure regulator in the line to the motor and a flow control valve in the inlet port. This way every point in the torque-speed graph can be set accurately.

Controlling the direction

The GLOBE vane air motors can be used both as a uni-directional and as a bi-directional air motor. When the air motor is used in a non-reversible application, it is sufficient to use a 2/2 or a 3/2 valve. For the reversible motor you can use either a 5/3 or two 3/2 valve to gain directional control.

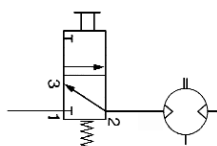

Uni-directional motor with 3/2 valve.

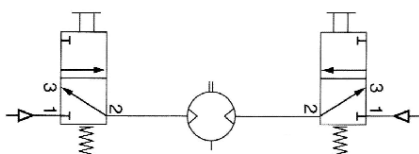

Bi-directional motor with two 3/2 valves.

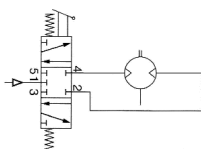

Bi-directional motor with 5/3 valve.

Advantages

GLOBE vane motors have a high starting torque, high efficiency and a superior power to weight ratio. Circular operation is possible even with a low number of revolutions. The motor can operate in two directions and is reversible in just a portion of a rotation. Permanent burdening in standstill is allowed. The GLOBE vane motors are insensitive to outside dirt and moist. All vanemotors are explosion-proof and are supplied with ATEX certification. Our vane motors can operate in all positions with a variable motorspeed.

Vane air motors offer a unique form of drive and incorporate advantages not found in other prime movers. They are instantly reversible when operated with a simple control valve. The speed and torque are variable and controlled with a simple and inexpensive flow control valve and/or pressure regulator. Vane air motors are suitable for running on natural sweet gas and other gasses and controllable over a wide speed range. With no shock start up, the life span of your equipment will improve. Lastly, the high variety of mounting interfaces makes them easy to install.

Applications

Vane air motors are used in numerous applications, most suitable for light tot medium duty operation at higher direct shaft speeds. Most typical vane air motor applications are:

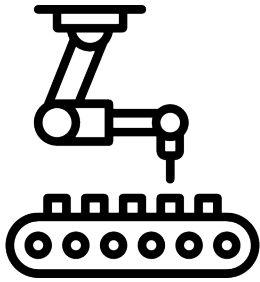

- Conveyor belts
- Packing machines
- Turntables

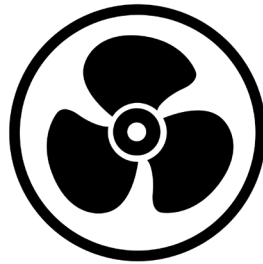

- After coolers
- Fans

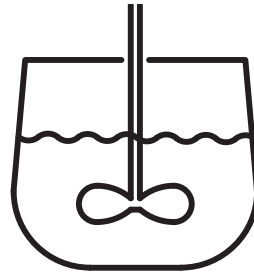

- Mixing equipment

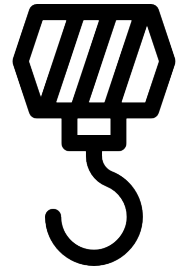

- Hoists
- Winches

Many accessories available

Our vane air motors can be completed with many accessories. For an air motor, clean air is very important. That's why we can supply everything you need to make sure your GLOBE vane air motor will maintain its maximum efficiency. Combine your air motor with a gearbox, control valve or brake to fit your needs. We also supply FRL systems and silencers which are a must-have for every air motor. We always recommend to combine a GLOBE vane air motor with GLOBE accessories to prevent loss of power or motor malfunctions. If you order your GLOBE air motor with our accessories, we can have it delivered to you completely assembled.

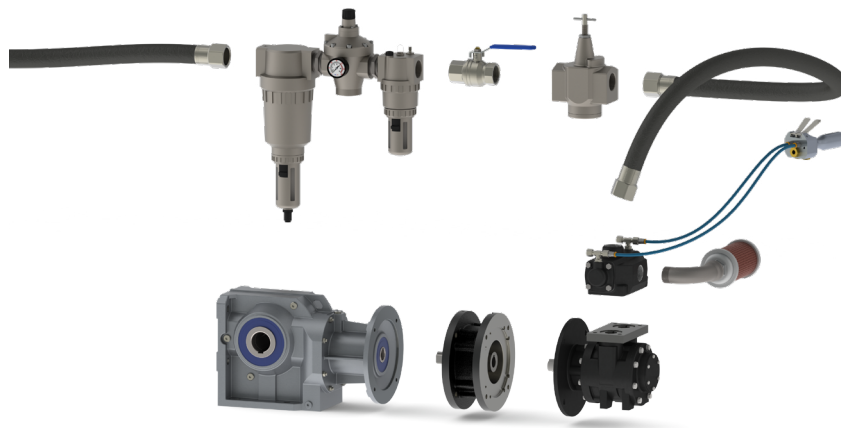

Also available in stainless steel or lubrication free.

The GLOBE vane air motors are available in various types and sizes, but are also available in stainless steel (INOX) and lubrication free.

Lubrication free

All our vane air motors are available for lubrication free applications. These motors are ideal for mixing applications because the absence of oil will result in a cleaner surrounding area. Oilless operation also means that surrounding equipment can't come in contact with contaminating aerosols .

Stainless steel

All our vane motors are available in stainless steel. The external parts of the vane motor are made of stainless steel. This makes it corrosion resistant and very suitable for hygienic applications. Our stainless steel vane motors are also lubrication free. Stainless steel vane motors are commonly used in the food industry, in mixing applications and the chemical industry.

Also available with gearbox

The GLOBE vane air motors can be controlled over a very wide speed range, but the output characteristics are not always ideal for your specific application. By mounting a gearbox to the air motor, specific speed and torque ranges can be selected. Our vane air motors are available with planetary, coaxial or worm gearbox. Check the available gearboxes for your desired vane air motor on it's page in this brochure.

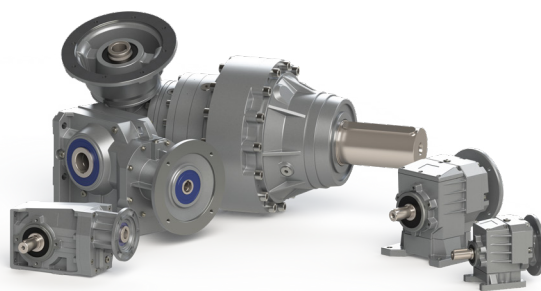

Important information when buying a vane air motor

Air line restrictions on the inlet side of the motor will result in performance loss. Therefore it is important to make sure that the desired air pressure is available at the motor during operation. The pressure reading at the compressor or pressure regulator may be different than the pressure available at the motor. Performance loss can also occur by an exhaust restriction generating back pressure on the outlet side of the motor. An insufficient sized silencer, valve or coupling is usually the cause. For every type of vane air motor we sell, we have the correct accessories available at GLOBE. If you combine your air motor with GLOBE accessories, you are ensured of a long service life.

How to use this catalogue

To help you decide which GLOBE vane air motor is best suited for your application, this catalogue provides you all the information you need. For every type of vane air motor, we have the following information available:

- Essential specifications and options
- Performance graphs
- Dimensional drawings
- Spare parts overview in exploded view

This catalogue concludes with an overview with all available accessories for our vane air motor. These accessories are selected to help you maintain your air motors maximum efficiency and service life. Do not hesitate to contact our specialists for more information or assistance, we are always happy to help!

info@globe-benelux.nl

How to select the right air motor

To be able to select the right air motor for your application, you will need at least two of the three following variables:

- Operating speed
- Torque
- Power

This will establish the so called 'working point' and will make selecting the right air motor easy. Once the working point has been established, the right air motor can be selected using the graphs included in the specifications of our vane air motors. Vane air motors have a wide operating range, so it is possible that multiple air motors fit your desired operating speed and torque.

Where motors are not required to start under load, such as fan drives, selection may be made using either Graph 1 or Graph 3 using the required running torque or power only. For applications where the motor starts under load, such as hoists, winches or track drives, the starting torque in Graph 2 must also be considered.

Our vane air motors can be combined with brakes and gearboxes, to achieve higher torques at lower speeds. Our specialist can always help you find the perfect air motor for your application. If you have questions about your motor selection, don't hesitate to contact us. We are happy to help you find the right solution for your application!

info@globe-benelux.nl

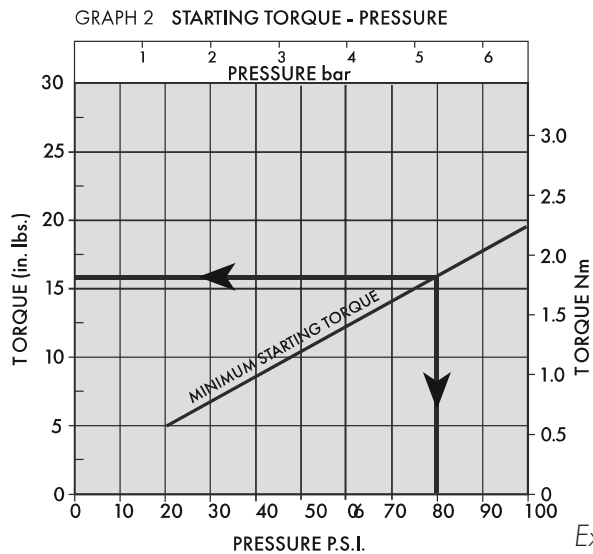
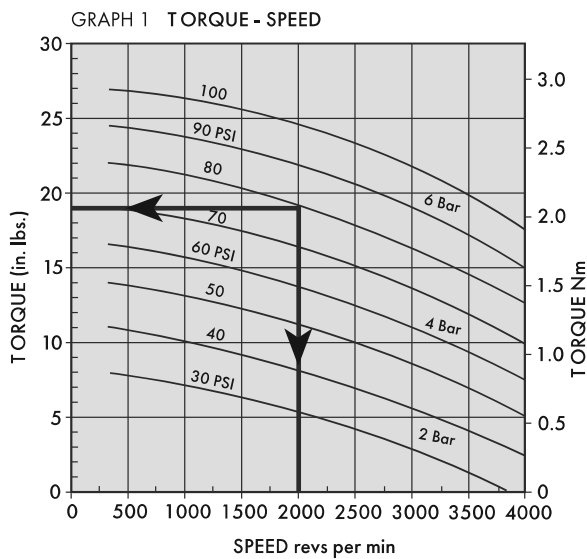

Example of the performance graphs for the V2 Vane Air Motor

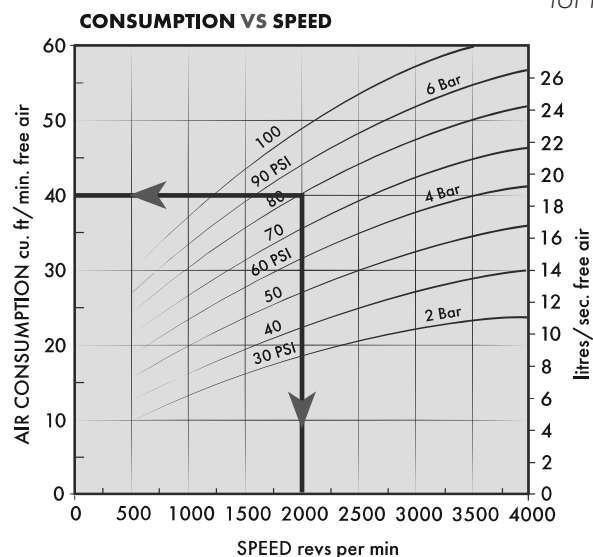
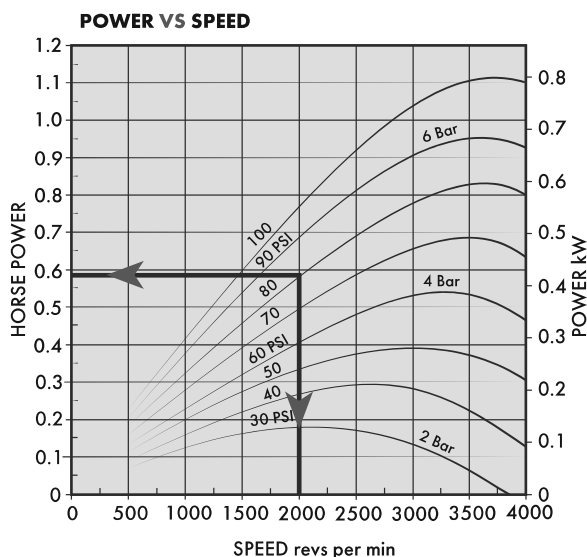

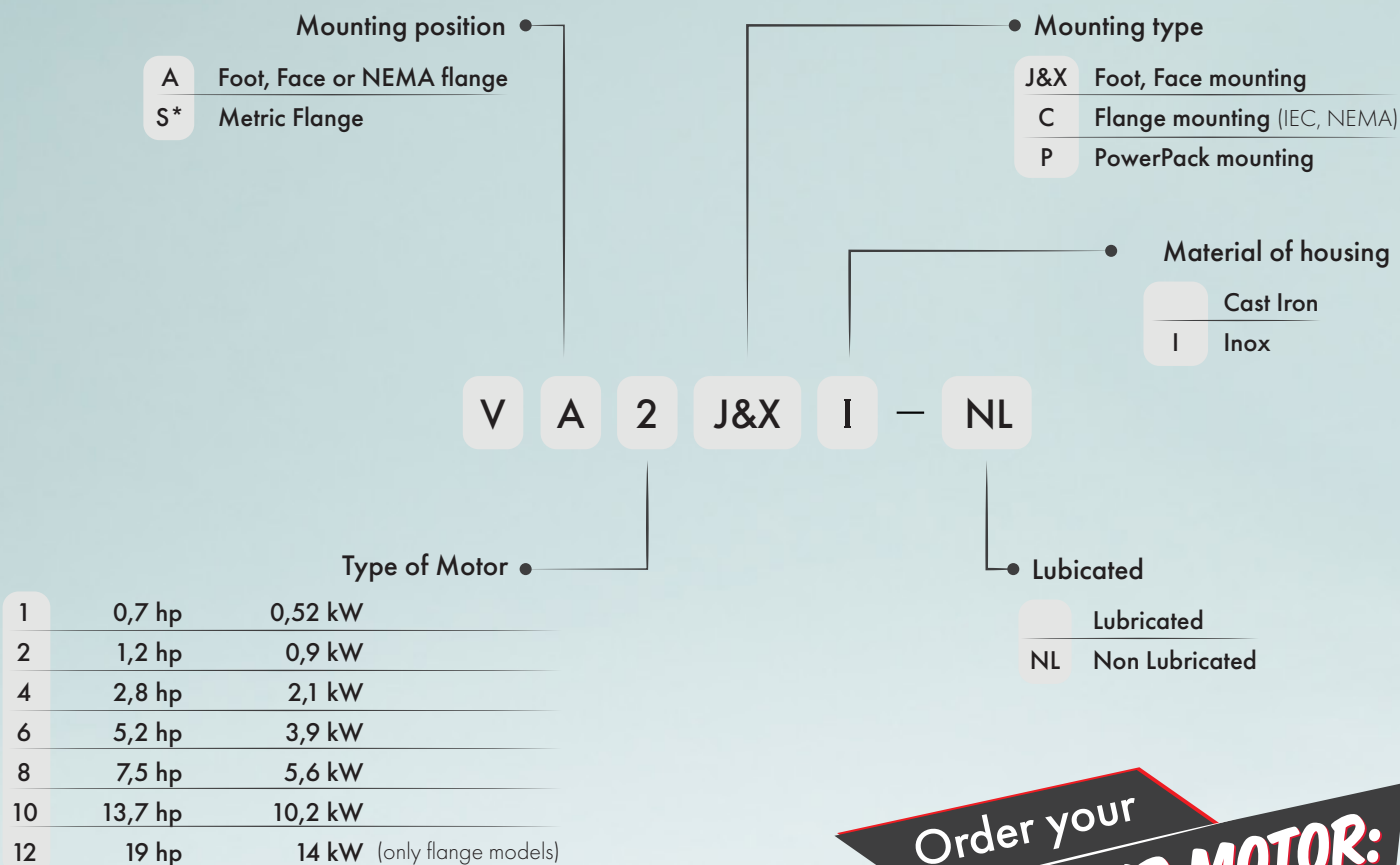

Ordering code

Select easily with the ordering code your version and order it at our sales team. Do you have special wishes? For example ATEX Certified, oil free, different mountings, gearboxes, brakes etc. You name it and we make it possible. Contact us for your wishes and we will be happy to engineer a proposal to suit your requirements.



Order your
VANE AIR MOTOR:
orders@globe-benelux.nl

All our Vane Air Motors are delivered with the ATEX Certificate:



II 2G Ex h IIC T4 Gb
II 2D Ex h IIIC T135°C Db
 -20° ≤ T_a ≤ +60°C

* The VS types are only available with mounting type C (for example VS8C).

V1 Vane Air Motor

Why buy the GLOBE V1 Vane Air Motor

Our V1 Vane Air Motors have a maximum power range of 0,52 kW (0.7 HP) with 0,84 Nm (7.4 in.lbs.) torque at max. power. The V1 is standard supplied according to the ATEX regulations. The power and speed are easily adjusted by pressure and air flow. These vane motors can be completed as desired with various accessories such as brakes, (control) valves and gearboxes.



A GLOBE Silencer is necessary for optimal reach of maximum power. Not installing a GLOBE Silencer will increase the risk of hearing damage, motor malfunctions or loss of power. It is also essential that an FRL unit is incorporated into the air-line to prevent motor malfunctions. Our silencers and FRL units are designed specifically for our motors to ensure maximum service life. Silencer is supplied with motor.

Versions of the V1 Vane Air Motor

Standard



Max. power	0.7 H.P. / 0,52 KW
Torque at max. power	7.4 in.lbs. / 0,84 Nm
Min. starting torque	6.8 in.lbs. / 0,77 Nm
Max. speed of rotation	6000 rpm
Mounting options	Hub / Flange

Non Lubricated



Max. power	0.54 H.P. / 0,40 KW
Torque at max. power	7.56 in.lbs. / 0,85 Nm
Min. starting torque	6.12 in.lbs. / 0,69 Nm
Max. speed of rotation	4500 rpm
Mounting options	Hub / Flange

Stainless Steel



Max. power	0.7 H.P. / 0,52 KW
Torque at max. power	7.4 in.lbs. / 0,84 Nm
Min. starting torque	6.8 in.lbs. / 0,77 Nm
Max. speed of rotation	6000 rpm
Mounting options	Hub / Flange

Which version do I need?

Our V1 Vane Air Motors are available as standard type, non lubricated or with a stainless steel housing. Our non lubricated vane air motors can run without lubrication under certain operating conditions. This makes them suitable for hygienic applications while saving on installation and annual running costs by not having to check oil levels.

Vane motors with stainless steel housing are widely used in the food, medical, pharmaceutical and chemical industries because of the hygienic aspect. They can be easily cleaned to keep your working environment sterile.

Geared vane air motor

Although our air motors can be adjusted over a wide range of speed and torque, the output characteristics may not always be suitable for the application. For lower speed applications, a gearbox can be coupled directly to the air motor. GLOBE Airmotors has a wide range of gear units available.

Dimensions VA1X / VS1C

- » Silencer supplied with motor
- » Max. Overhung Force on shaft 18 N (4.0 lbf.)
- » Axial loads should be kept to a minimum
- » Maximum temperature for ATEX applications -20°C to +60°C (-4°F to +140°F)
- » Maximum temperature for non-ATEX applications -20°C to +80°C (-4°F to +176°F)

VA1X

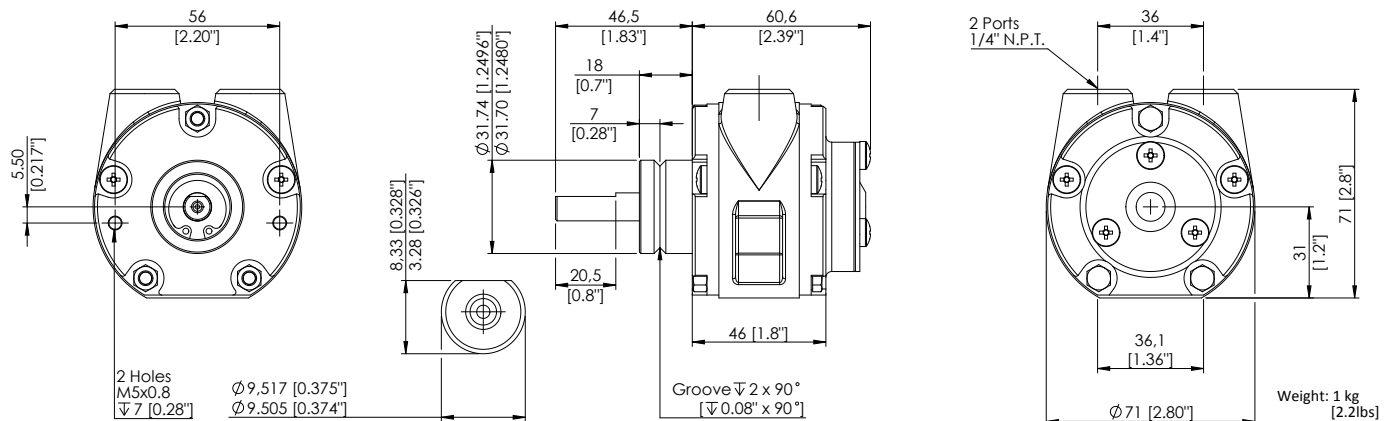

VS1C (IEC56 B5 Configuration)

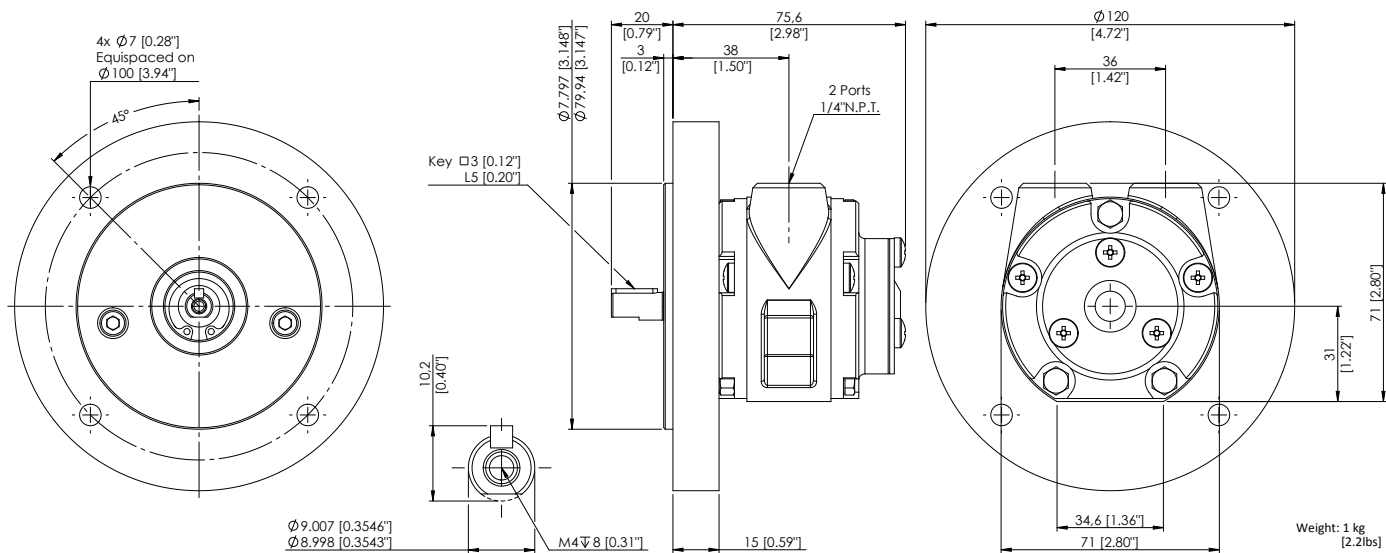

Performance V1 / V1-INOX

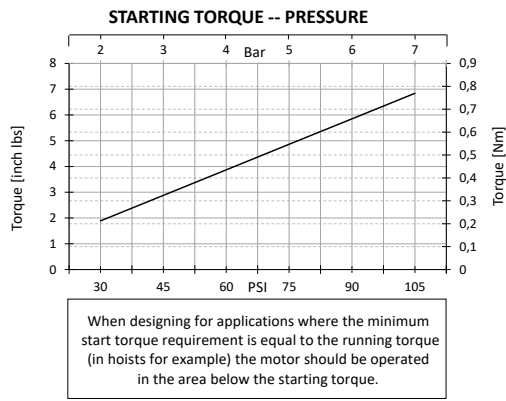
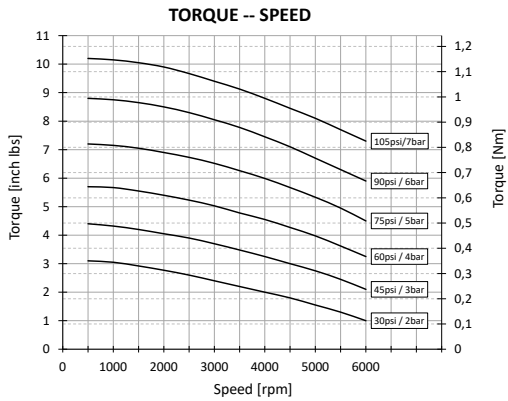

- » Silencer supplied with motor.
- » Motor is reversible.
- » Maximum temperature for ATEX applications: -20°C to +60°C (-4°F to +140°F)
- » Maximum temperature for non-ATEX applications: -20°C to +80°C (-4°F to +176°F)

Air supply lubrication and filtration:

Use 64 micron filtration or better. Choose a lubricator suitable for the flow required. Prior to initial startup, inject oil into the inlet port.

Lubricator drop rate 2-3 drop / minute continuous operations
Lubricator drop rate 4-6 drop / minute intermittent operation.

Maximum speed 6000 rpm

Life time depends highly on operational speed and air pressure.

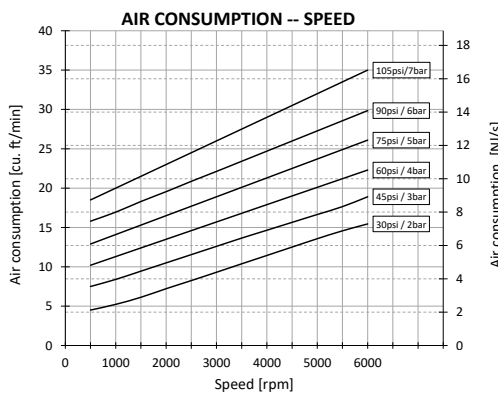
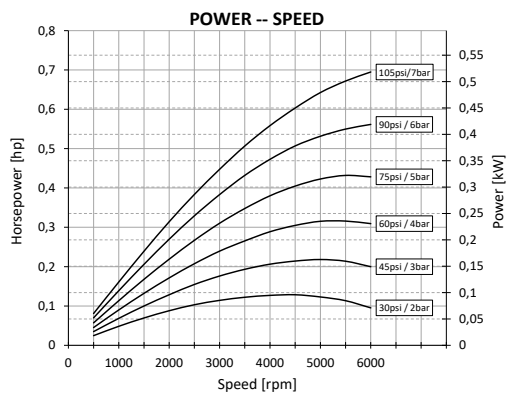

Performance V1-Non Lubricated

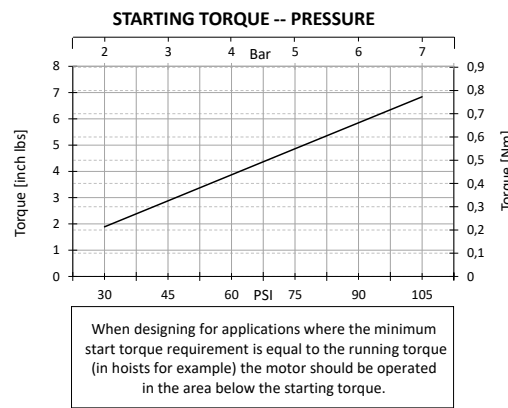
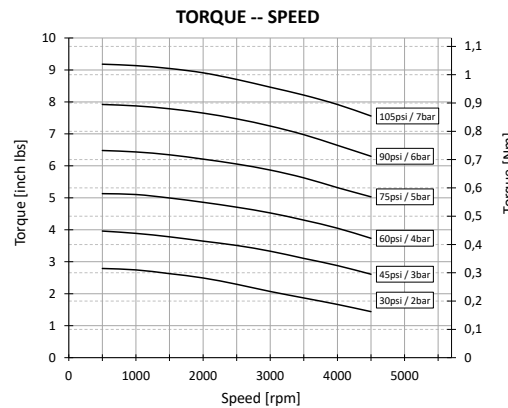

- » Silencer supplied with motor.
- » Motor is reversible.
- » Maximum temperature for ATEX applications: -20°C to +60°C (-4°F to +140°F)
- » Maximum temperature for non-ATEX applications: -20°C to +80°C (-4°F to +176°F)

Air quality and filtration:

Use 5 micron filtration. The air has to be dry to prevent corrosion inside the motor when it is not in use. Advisable is to use an air dryer with set point of 20 degrees Celsius below lowest ambient temperature.

Maximum speed 4500 rpm

Continuous speed 3000 rpm
Life time depends highly on operational speed and air pressure. Continuous duty is best suited to non lubricated operation. Moisture in the air can cause corrosion problems during rest periods.

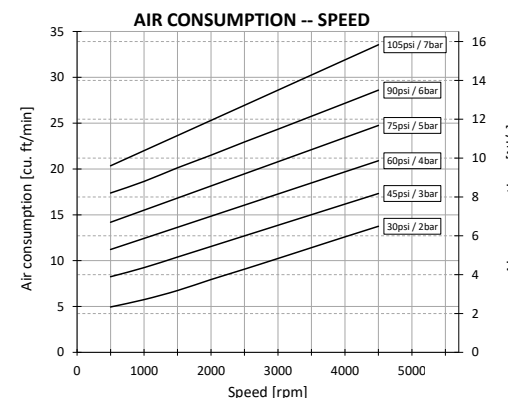
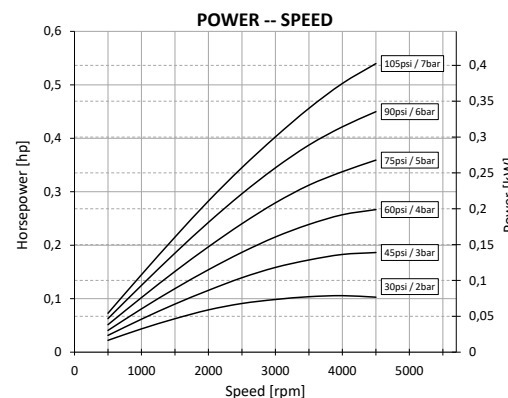

Spare Parts VA1X / VS1C

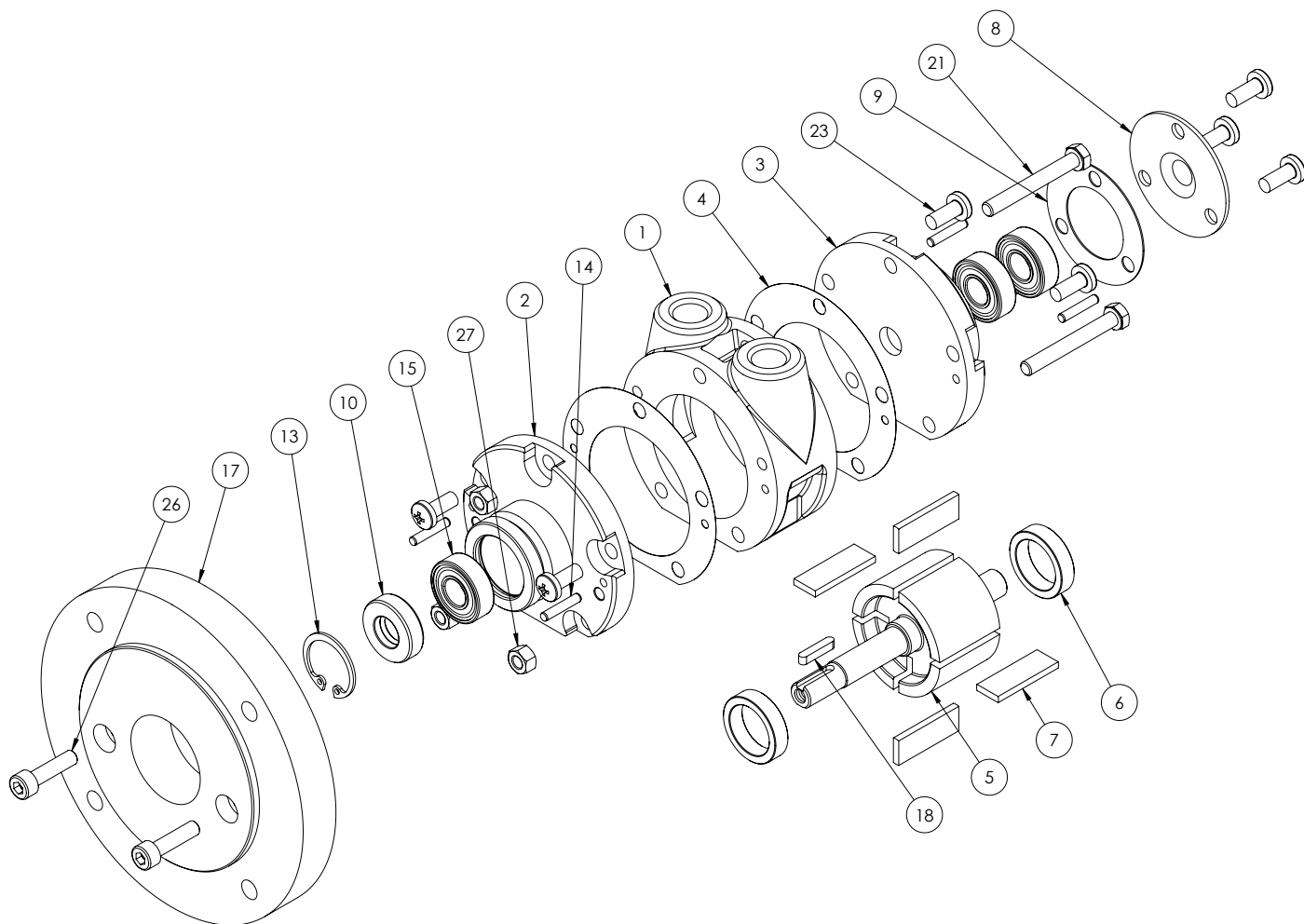

Item	Part No.	Description	Qty	Kit No.
1	710-001	Body NPT	1	
2	710-003	Front plate	1	
3	710-002	Back plate	1	
4	710-062	Gasket		719-910 / 719-915
5	710-911	Rotor (VA1X)	1	
5	-	Rotor (VS1C)	1	
6	710-006	Ejection ring	2	
7	710-005	Rotor blade	4	719-910 / 719-915
8	710-008	Cover plate	1	
9	710-009	Gasket	1	719-910 / 719-915
10	808-065	Shaft seal	1	719-910 / 719-915
13	804-044	Circlip	1	719-910 / 719-915
14	806-009	Dowel pin	4	
15	807-053	Bearing	3	
17	-	Flange IEC56 B5 (VS1C)	1	
18	-	Key (VS1C)	1	
21	802-700	Screw	3	
23	805-050	Screw	4	
26	-	Screw (VS1C)	2	
27	801-700	Nut	3	
	719-910	V1 Service Kit		
	719-915	VI-NL Service Kit		



V2 Vane Air Motor

Why buy the GLOBE V2 Vane Air Motor

Our V2 Vane Air Motors have a maximum power range of 0,88 kW (1.18 HP) with 2,3 Nm (20 in.lbs.) torque at max. power. The V2 is standard supplied according to the ATEX regulations. The power and speed are easily adjusted by pressure and air flow. These vane motors can be completed as desired with various accessories such as brakes, (control) valves and gearboxes.



A GLOBE Silencer is necessary for optimal reach of maximum power. Not installing a GLOBE Silencer will increase the risk of hearing damage, motor malfunctions or loss of power. It is also essential that an FRL unit is incorporated into the air-line to prevent motor malfunctions. Our silencers and FRL units are designed specifically for our motors to ensure maximum service life. Silencer is supplied with motor.

Versions of the V2 Vane Air Motor

Standard



Max. power	1.18 H.P. / 0,88 KW
Torque at max. power	18.5 in.lbs. / 2,1 Nm
Min. starting torque	20 in.lbs. / 2,3 Nm
Max. speed of rotation	4000 rpm
Mounting options	Hub / Flange / Feet / IEC

Non Lubricated



Max. power	0.97 H.P. / 0,72 KW
Torque at max. power	20.4 in.lbs. / 2,3 Nm
Min. starting torque	18 in.lbs. / 2,03 Nm
Max. speed of rotation	3000 rpm
Mounting options	Hub / Flange / Feet / IEC

Stainless Steel



Max. power	1.18 H.P. / 0,88 KW
Torque at max. power	18.5 in.lbs. / 2,1 Nm
Min. starting torque	20 in.lbs. / 2,3 Nm
Max. speed of rotation	4000 rpm
Mounting options	Hub / Flange / Feet / IEC

Which version do I need?

Our V2 Vane Air Motors are available as standard type, non lubricated or with a stainless steel housing. Our non lubricated vane air motors can run without lubrication under certain operating conditions. This makes them suitable for hygienic applications while saving on installation and annual running costs by not having to check oil levels.

Vane motors with stainless steel housing are widely used in the food, medical, pharmaceutical and chemical industries because of the hygienic aspect. They can be easily cleaned to keep your working environment sterile.

Geared vane air motor

Although our air motors can be adjusted over a wide range of speed and torque, the output characteristics may not always be suitable for the application. For lower speed applications, a gearbox can be coupled directly to the air motor. GLOBE Airmotors has a wide range of gear units available.

Dimensions V2

- » Maximum temperature for ATEX applications
-20°C to +60°C (-4°F to +140°F)
- » Maximum temperature for non-ATEX applications
-20°C to +80°C (-4°F to +176°F)

- » Silencer supplied with motor
- » Max. Overhung Force on shaft 400 N (90 lbf.)
- » Axial loads should be kept to a minimum

VS2C (IEC71 B5 Configuration)

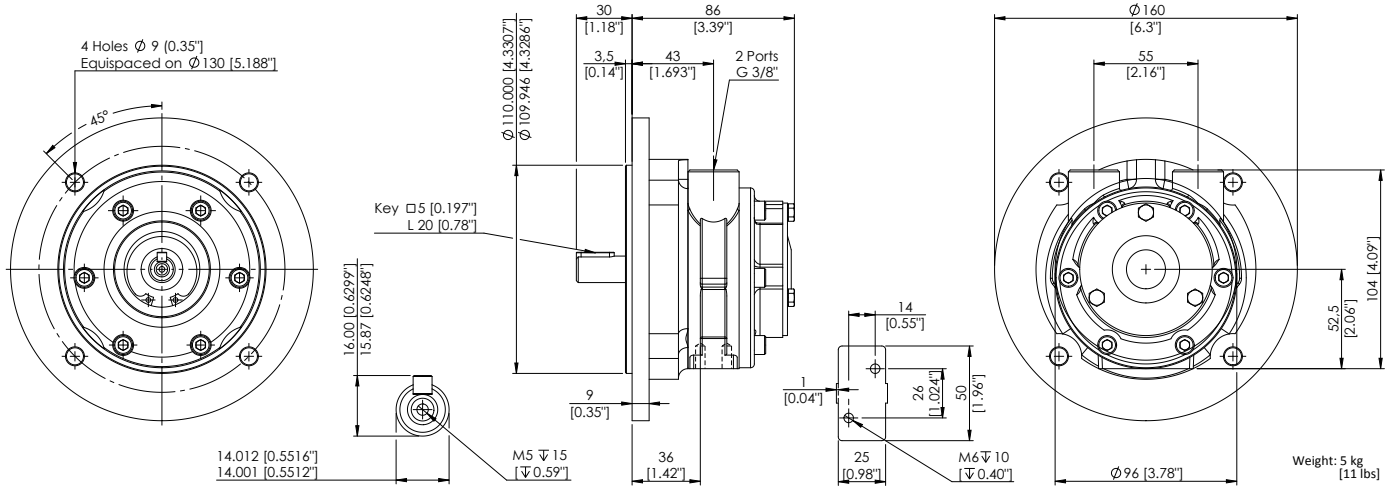

» Also available with IEC71 B14

VA2J&X

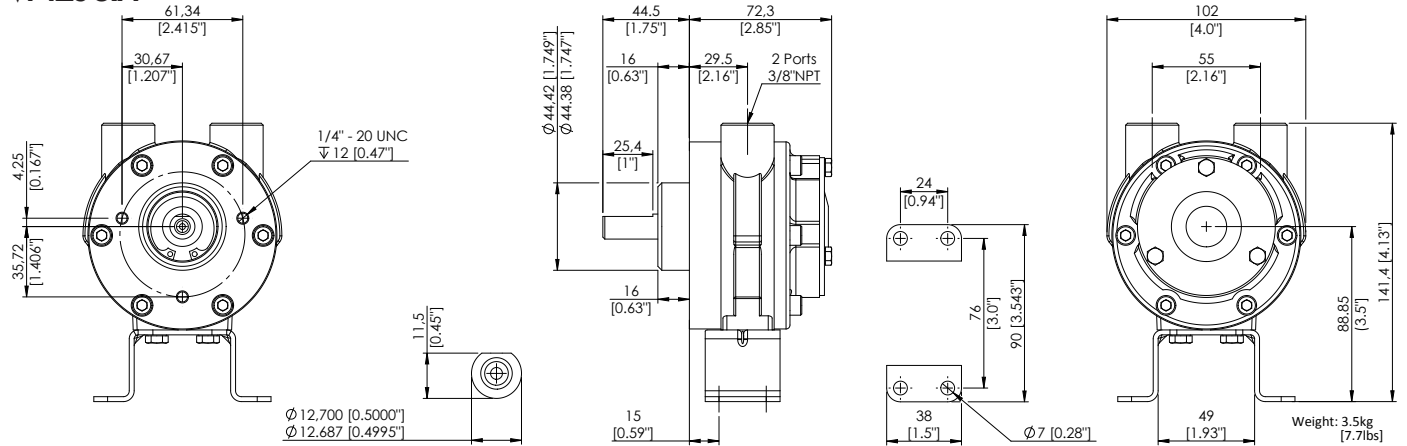

*Foot supplied loose with motor

VA2C (NEMA 56C Configuration)

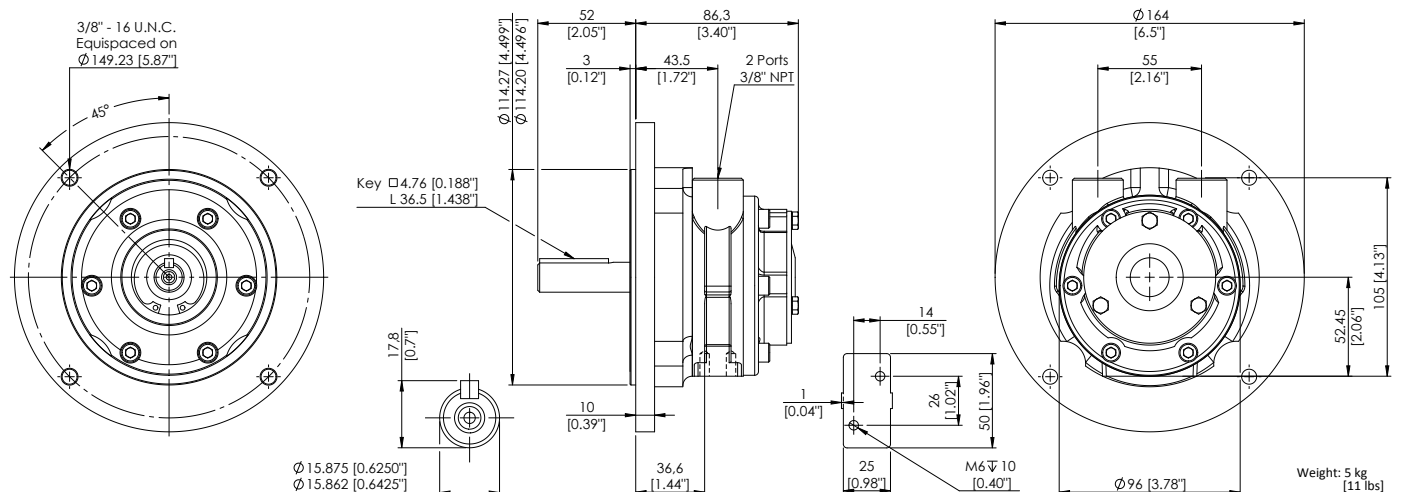

Performance V2 / V2-INOX

TORQUE -- SPEED

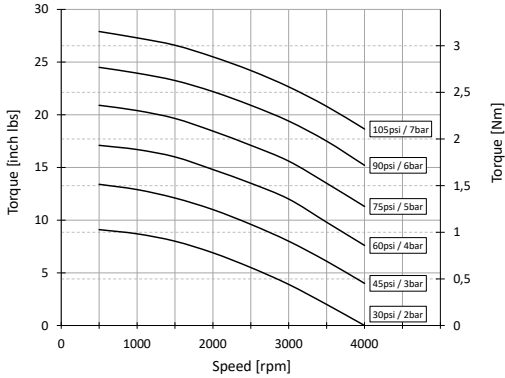

STARTING TORQUE -- PRESSURE

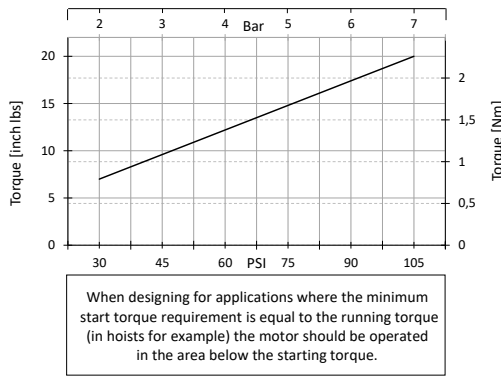

POWER -- SPEED

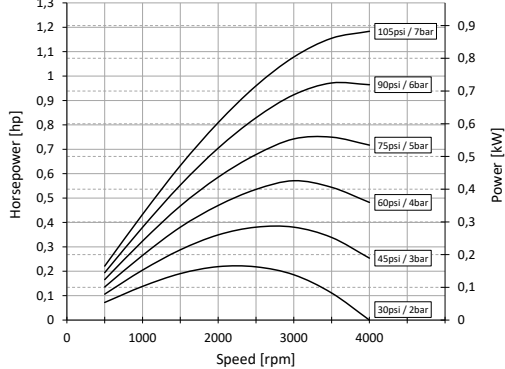

AIR CONSUMPTION -- SPEED

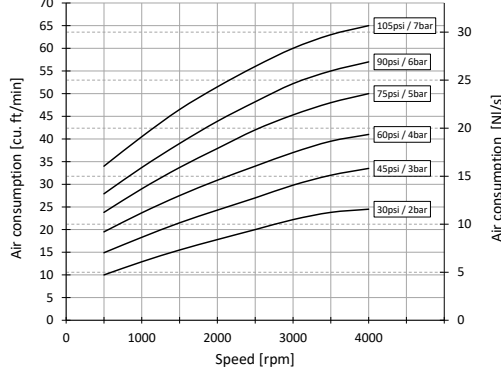

- » Silencer supplied with motor.
- » Motor is reversible.
- » Maximum temperature for ATEX applications: -20°C to +60°C (-4°F to +140°F)
- » Maximum temperature for non-ATEX applications: -20°C to +80°C (-4°F to +176°F)

Airsupply lubrication and filtration:

Use 64 micron filtration or better. Choose a lubricator suitable for the flow required. Prior to initial startup, inject oil into the inlet port.

Lubricator drop rate 3-4 drop / minute continuous operations
 Lubricator drop rate 6-8 drop / minute intermittent operation.

Maximum speed 4000 rpm

Life time depends highly on operational speed and air pressure.

Performance V2-Non Lubricated

TORQUE -- SPEED

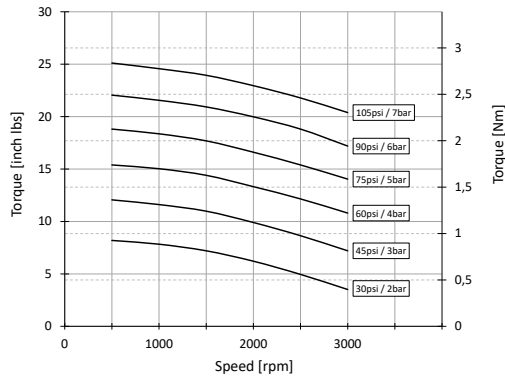

STARTING TORQUE -- PRESSURE

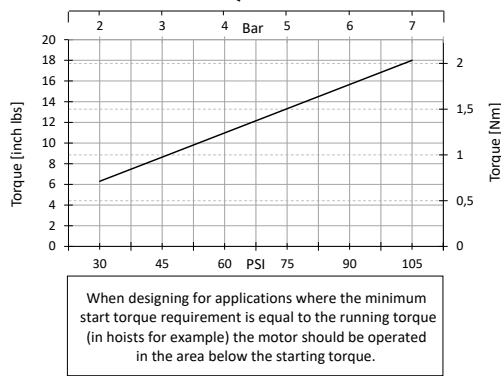

POWER -- SPEED

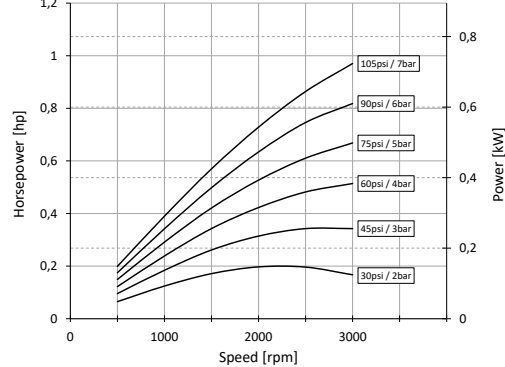

AIR CONSUMPTION -- SPEED

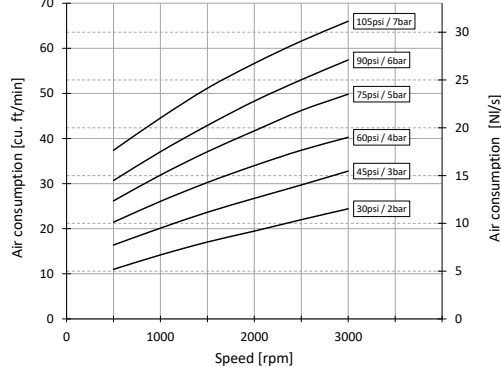

- » Silencer supplied with motor.
- » Motor is reversible.
- » Maximum temperature for ATEX applications: -20°C to +60°C (-4°F to +140°F)
- » Maximum temperature for non-ATEX applications: -20°C to +80°C (-4°F to +176°F)

Air quality and filtration:

Use 5 micron filtration. The air has to be dry to prevent corrosion inside the motor when it is not in use. Advisable is to use an air dryer with set point of 20 degrees Celsius below lowest ambient temperature.

Maximum speed 3000 rpm

Continuous speed 2000 rpm
 Life time depends highly on operational speed and air pressure. Continuous duty is best suited to non lubricated operation. Moisture in the air can cause corrosion problems during rest periods.

Spare Parts VA2J&X

Item	Part No.	Description	Qty	Kit No.
1	720-001	Body NPT	1	
2	740-003	Front plate	1	
3	740-002	Back plate	1	
4	740-062	Gasket		729-910 / 729-915
5	720-911	Rotor	1	
6	720-006	Ejection ring	2	
7	720-105	Rotor blade	4	729-910 / 729-915
8	740-008	Cover plate	1	
9	808-030	O-ring	1	729-910 / 729-915
10	808-051	Shaft seal	1	729-910 / 729-915
11	740-100	Seal backing ring	1	
13	804-049	Circlip	1	729-910 / 729-915
14	806-024	Dowel pin	2	
15	807-027	Bearing	1	
16	807-028	Bearing	1	
19	720-023	Foot (VA2J only)	1	
20	806-032	Dowel pin	2	
21A	809-007	Screw	4	
21B	809-007P	Screw	8	
23	802-001	Screw	3	
25	802-011	Screw (VA2J only)	2	
729-910		V2 Service Kit		
729-915		V2-NL Service Kit		

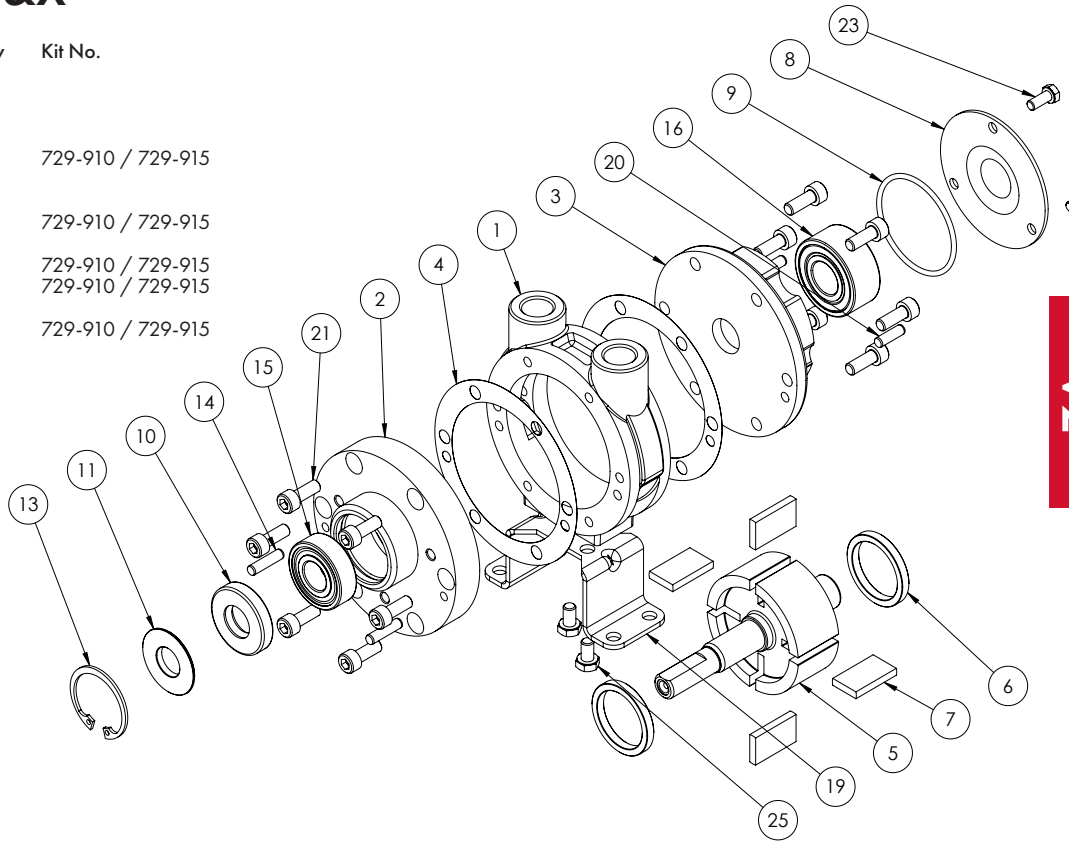

V2

Spare Parts VA2C / VS2C

Item	Part No.	Description	Qty	Kit No.
1	720-001	Body NPT	1	
1	720-101	Body BSP (VS2C)	1	
2	740-018	Front plate	1	
2	740-035	Front plate (VS2C)	1	
3	740-002	Back plate	1	
4	740-062	Gasket		729-910 / 729-915
5	720-910	Rotor	1	
5	720-920	Rotor (VS2C)	1	
6	720-006	Ejection ring	2	
7	720-105	Rotor blade	4	729-910 / 729-915
8	740-008	Cover plate	1	
9	808-030	O-ring	1	729-910 / 729-915
10	808-054	Shaft seal	1	729-910 / 729-915
11	720-100	Seal backing ring	1	
13	804-052	Circlip	1	729-910 / 729-915
14	806-024	Dowel pin	4	
15	807-025	Bearing	1	
16	807-028	Bearing	1	
18	811-020	Key	1	
18	811-027	Key (VS2C)	1	
21A	809-007	Screw	4	
21B	809-007P	Screw	8	
23	802-001	Screw	3	
729-910		V2 Service Kit		
729-915		V2-NL Service Kit		

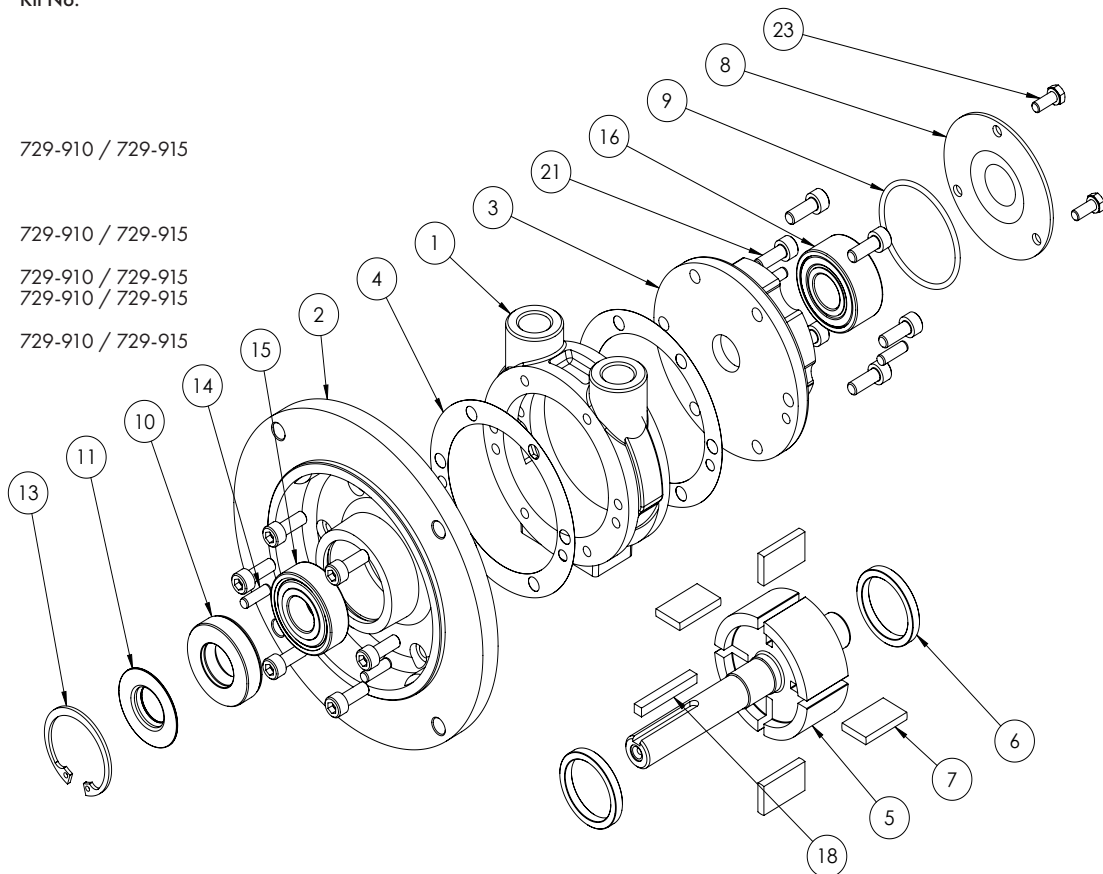

V4 Vane Air Motor

Why buy the GLOBE V4 Vane Air Motor

Our V4 Vane Air Motors have a maximum power range of 2,1 kW (2.8 HP) with 5,06 Nm (3.7 ft.lbs.) torque at max. power. The V4 is standard supplied according to the ATEX regulations. The power and speed are easily adjusted by pressure and air flow. These vane motors can be completed as desired with various accessories such as brakes, (control) valves and gearboxes.



A GLOBE Silencer is necessary for optimal reach of maximum power. Not installing a GLOBE Silencer will increase the risk of hearing damage, motor malfunctions or loss of power. It is also essential that an FRL unit is incorporated into the air-line to prevent motor malfunctions. Our silencers and FRL units are designed specifically for our motors to ensure maximum service life. Silencer is supplied with motor.

Versions of the V4 Vane Air Motor

Standard



Max. power	2.8 H.P. / 2,1 KW
Torque at max. power	3.7 ft.lbs. / 5,02 Nm
Min. starting torque	3.6 ft.lbs. / 4,88 Nm
Max. speed of rotation	4000 rpm
Mounting options	Hub / Flange / Feet / IEC

Non Lubricated



Max. power	2.13 H.P. / 1,6 KW
Torque at max. power	3.7 ft.lbs. / 5,06 Nm
Min. starting torque	3.2 ft.lbs. / 4,4 Nm
Max. speed of rotation	3000 rpm
Mounting options	Hub / Flange / Feet / IEC

Stainless Steel



Max. power	2.8 H.P. / 2,1 KW
Torque at max. power	3.7 ft.lbs. / 5,02 Nm
Min. starting torque	3.6 ft.lbs. / 4,88 Nm
Max. speed of rotation	4000 rpm
Mounting options	Hub / Flange / Feet / IEC

Which version do I need?

Our V4 Vane Air Motors are available as standard type, non lubricated or with a stainless steel housing. Our non lubricated vane air motors can run without lubrication under certain operating conditions. This makes them suitable for hygienic applications while saving on installation and annual running costs by not having to check oil levels.

Vane motors with stainless steel housing are widely used in the food, medical, pharmaceutical and chemical industries because of the hygienic aspect. They can be easily cleaned to keep your working environment sterile.

Geared vane air motor

Although our air motors can be adjusted over a wide range of speed and torque, the output characteristics may not always be suitable for the application. For lower speed applications, a gearbox can be coupled directly to the air motor. GLOBE Airmotors has a wide range of gear units available.

Dimensions V4

- » Maximum temperature for ATEX applications
-20°C to +60°C (-4°F to +140°F)
- » Maximum temperature for non-ATEX applications
-20°C to +80°C (-4°F to +176°F)

- » Silencer supplied with motor
- » Max. Overhung Force on shaft 170 N (40 lbf.)
- » Axial loads should be kept to a minimum

VS4C (IEC71 B5 Configuration)

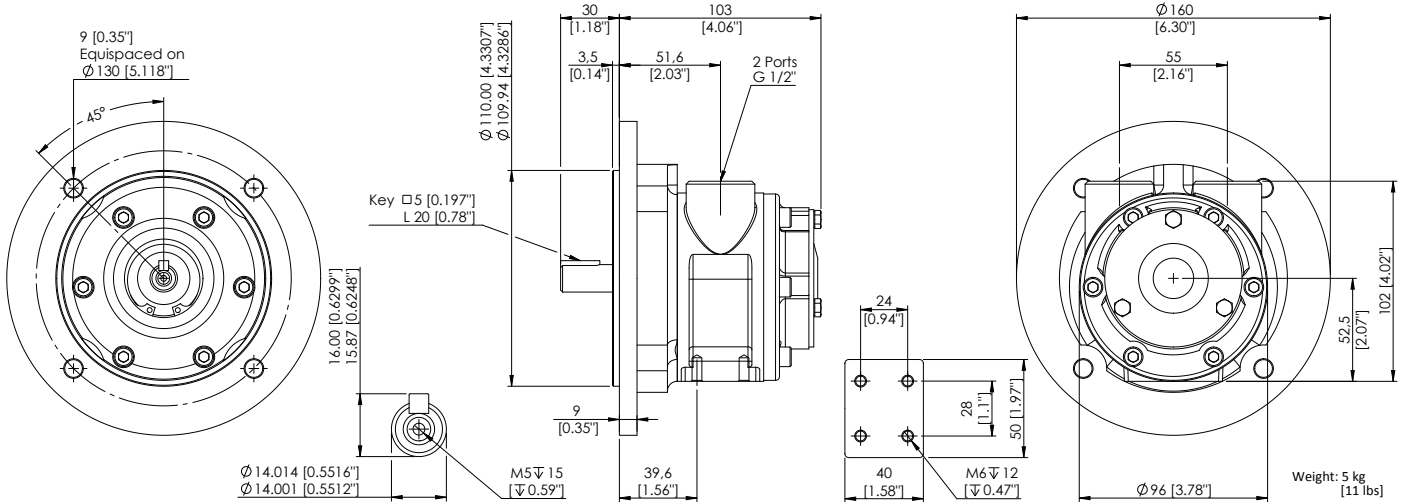

» Also available with IEC71 B14

VA4J&X

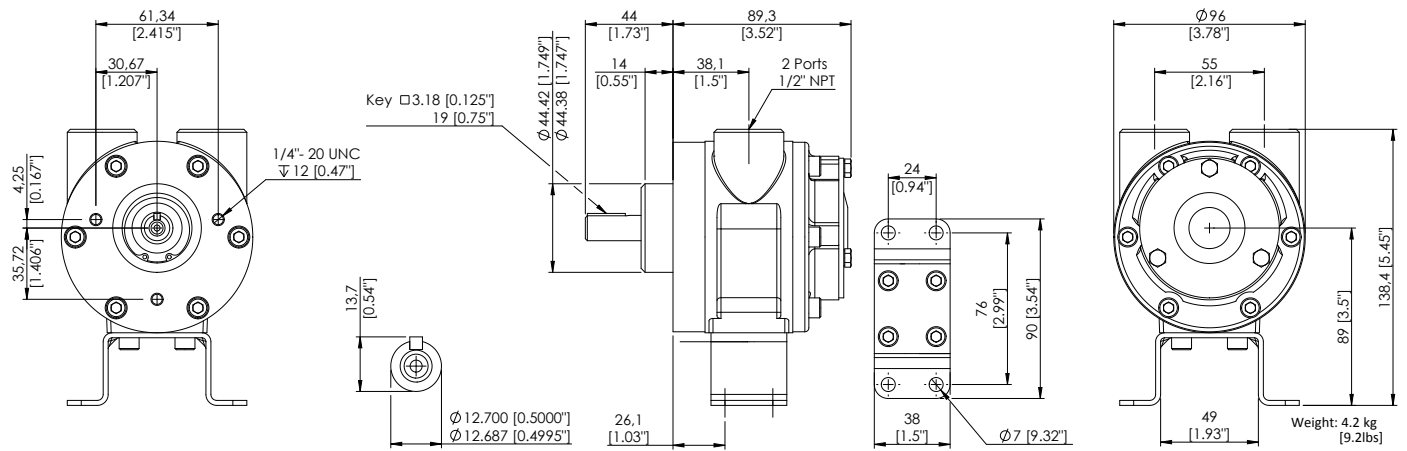

*Foot supplied loose with motor

VA4C (NEMA 56C Configuration)

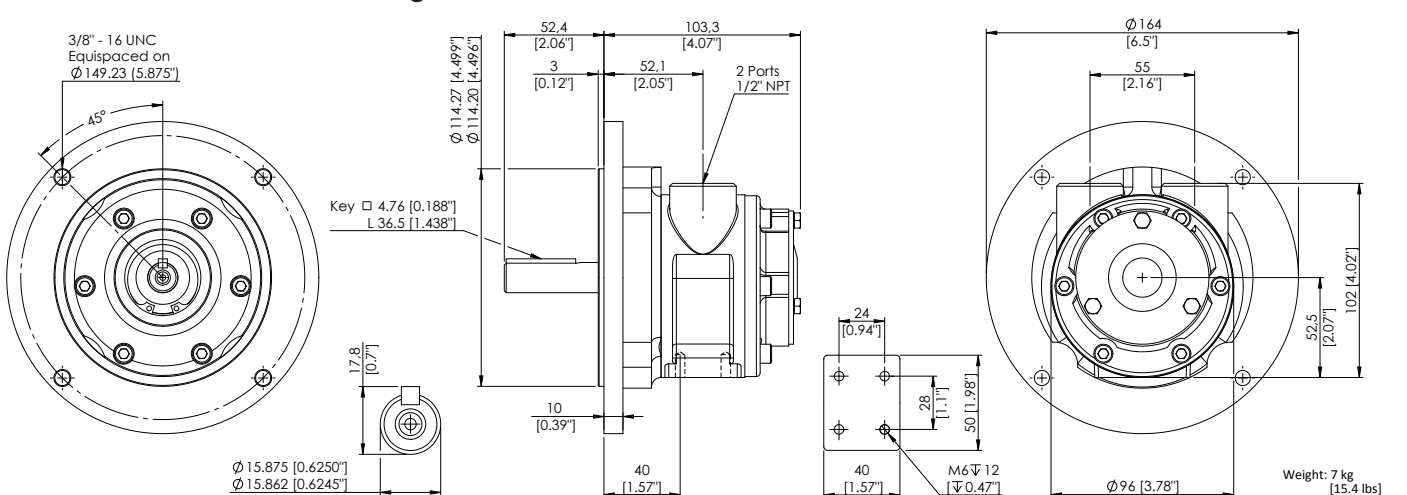

Performance V4 / V4-INOX

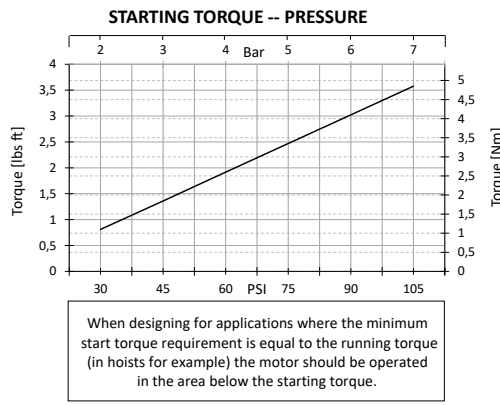
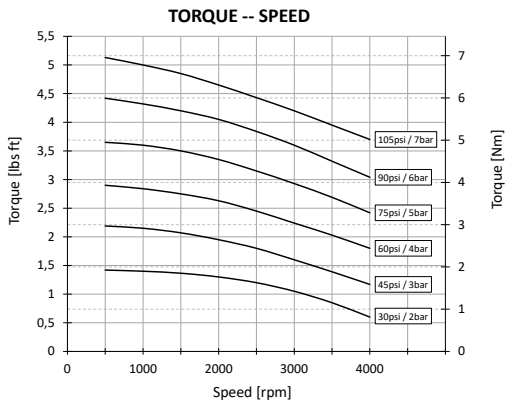

- » Silencer supplied with motor.
- » Motor is reversible.
- » Maximum temperature for ATEX applications: -20°C to +60°C (-4°F to +140°F)
- » Maximum temperature for non-ATEX applications: -20°C to +80°C (-4°F to +176°F)

Airsupply lubrication and filtration:

Use 64 micron filtration or better. Choose a lubricator suitable for the flow required. Prior to initial startup, inject oil into the inlet port.

Lubricator drop rate 4-5 drop / minute continuous operations
Lubricator drop rate 9-12 drop / minute intermittent operation.

Maximum speed 4000 rpm

Life time depends highly on operational speed and air pressure.

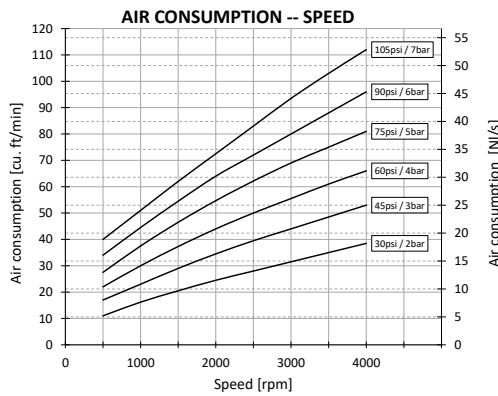
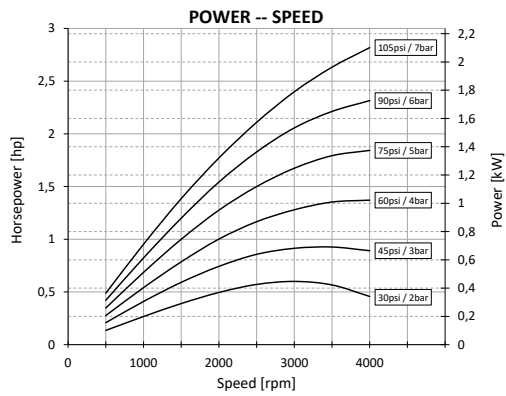

Performance V4-Non Lubricated

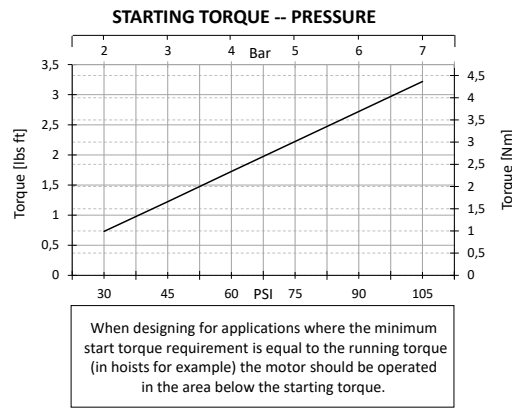
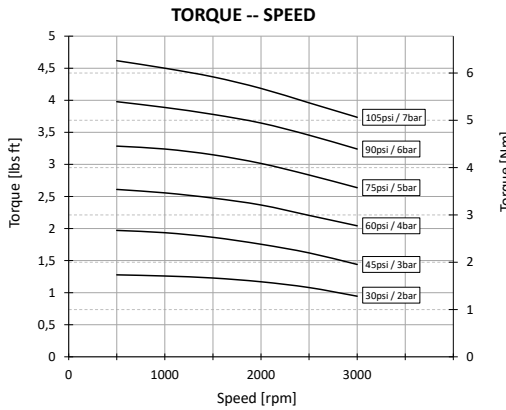

- » Silencer supplied with motor.
- » Motor is reversible.
- » Maximum temperature for ATEX applications: -20°C to +60°C (-4°F to +140°F)
- » Maximum temperature for non-ATEX applications: -20°C to +80°C (-4°F to +176°F)

Air quality and filtration:

Use 5 micron filtration. The air has to be dry to prevent corrosion inside the motor when it is not in use. Advisable is to use an air dryer with set point of 20 degrees Celsius below lowest ambient temperature.

Maximum speed 3000 rpm

Continuous speed 2000 rpm
Life time depends highly on operational speed and air pressure. Continuous duty is best suited to non lubricated operation. Moisture in the air can cause corrosion problems during rest periods.

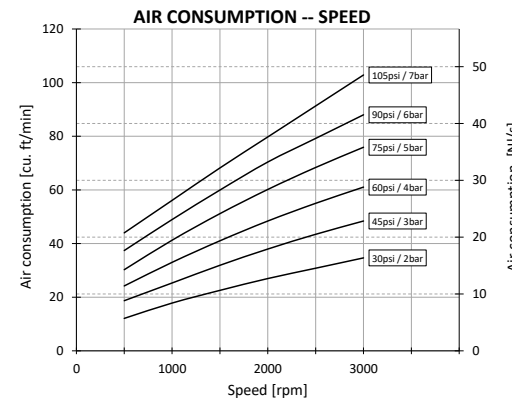
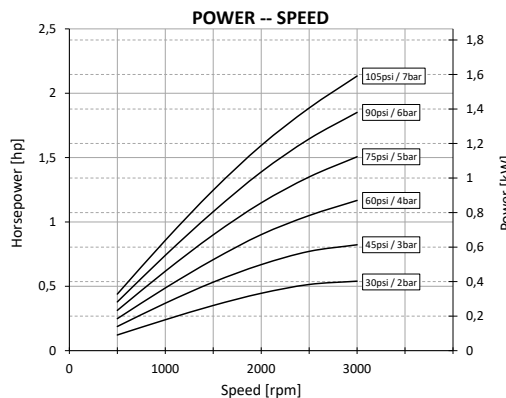

Spare Parts VA4J&X

Item	Part No.	Description	Qty	Kit No.
1	740-001	Body NPT	1	
2	740-003	Front plate	1	
3	740-002	Back plate	1	
4	740-062	Gasket	1	749-910 / 749-915
5	740-911	Rotor	1	
6	740-006	Ejection ring	2	
7	740-105	Rotor blade	4	749-910 / 749-915
8	740-008	Cover plate	1	
9	808-030	O-ring	1	749-910 / 749-915
10	808-051	Shaft seal	1	749-910 / 749-915
11	740-100	Seal backing ring	1	
13	804-049	Circlip	1	749-910 / 749-915
14	806-024	Dowel pin	2	
15	807-027	Bearing	1	
16	807-028	Bearing	1	
18	811-023	Key	1	
19	740-023	Foot (VA4J only)	1	
20	806-032	Dowel pin	2	
21A	809-007	Screw	8	
21B	809-007P	Screw	4	
23	802-001	Screw	3	
25	802-011	Screw	4	
	749-910	V4 Service Kit		
	749-915	V4-NL Service Kit		

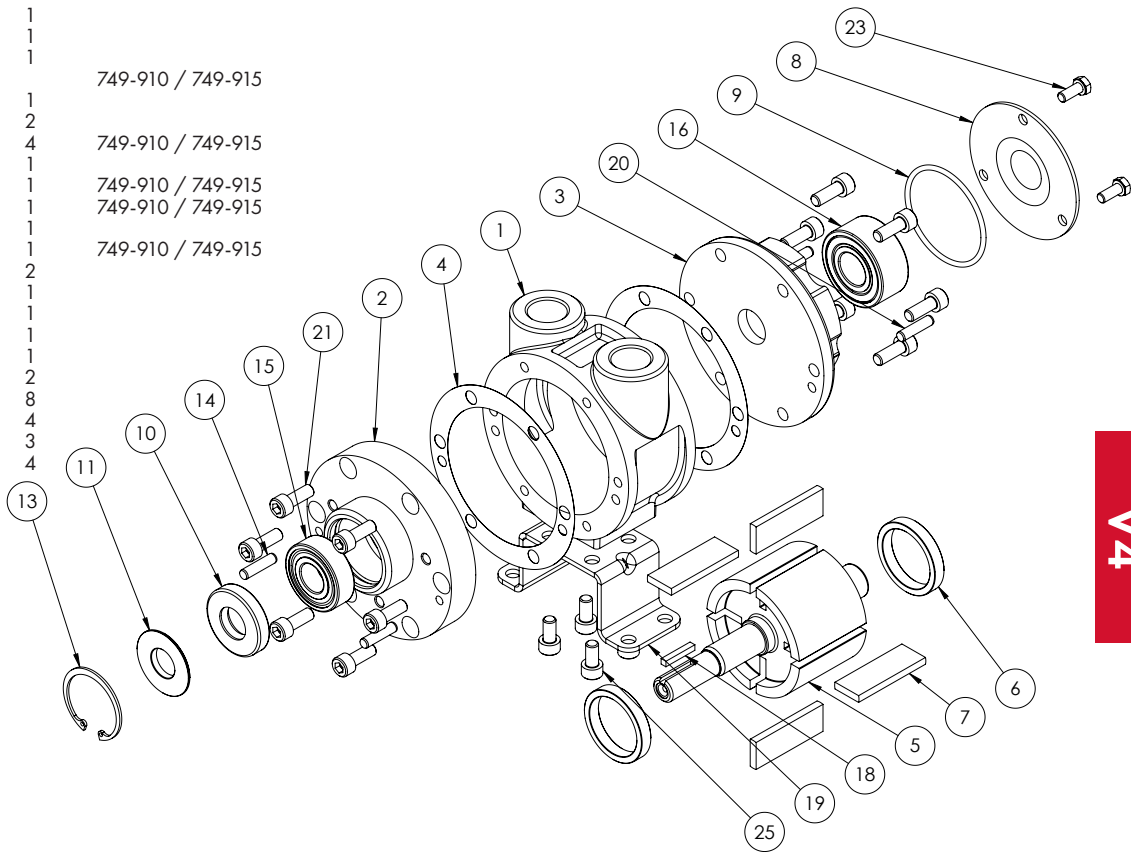

Spare Parts VA4C & VS4C

Item	Part No.	Description	Qty	Kit No.
1	740-001	Body NPT	1	
1	740-101	Body BSP (VS4C)	1	
2	740-018	Front plate	1	
2	740-035	Front plate (VS4C)	1	
3	740-002	Back plate	1	
4	740-062	Gasket	1	749-910 / 749-915
5	740-910	Rotor	1	
5	740-920	Rotor (VS4C)	1	
6	740-006	Ejection ring	2	
7	740-105	Rotor blade	4	749-910 / 749-915
8	740-008	Cover plate	1	
9	808-030	O-ring	1	749-910 / 749-915
10	808-054	Shaft seal	1	749-910 / 749-915
11	720-100	Seal backing ring	1	
13	804-052	Circlip	1	749-910 / 749-915
14	806-024	Dowel pin	4	
15	807-025	Bearing	1	
16	807-028	Bearing	1	
18	811-020	Key	1	
18	811-027	Key (VS4C)	1	
21A	809-007	Screw	8	
21B	809-007P	Screw	4	
23	802-001	Screw	3	
	749-910	V4 Service Kit		
	749-915	V4-NL Service Kit		

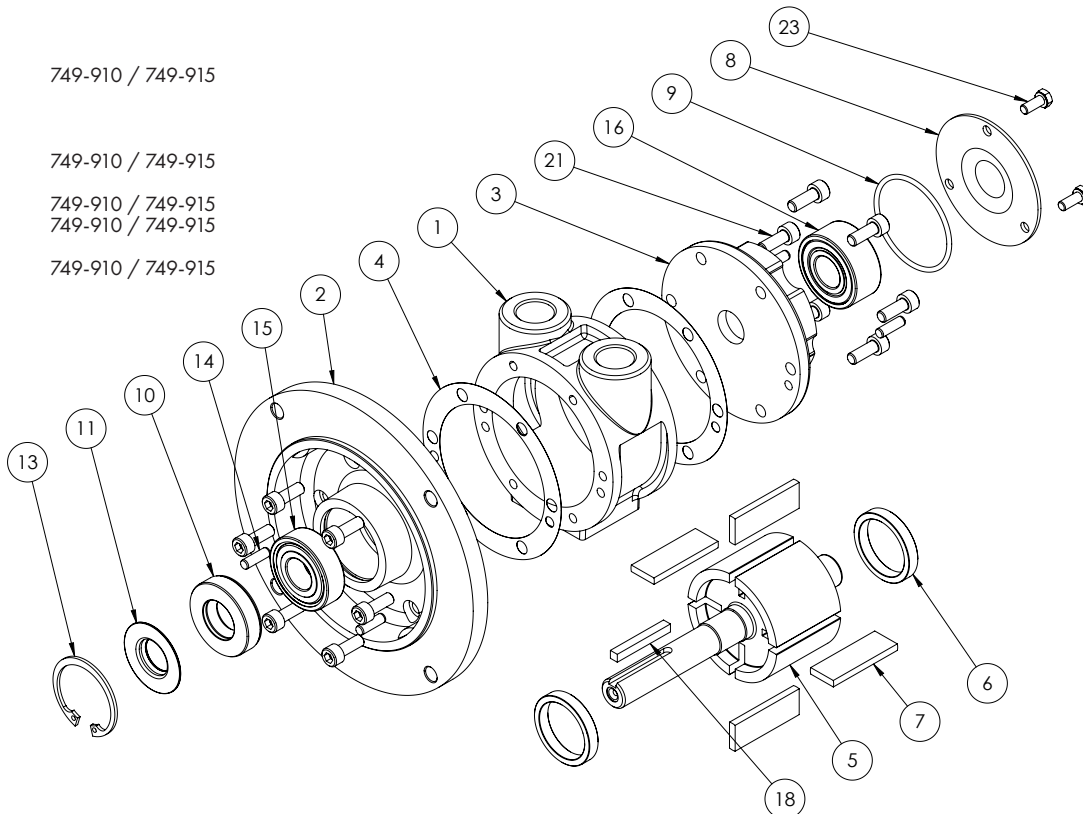

V6 Vane Air Motor

Why buy the GLOBE V6 Vane Air Motor

Our V6 Vane Air Motors have a maximum power range of 3,9 kW (5.2 HP) with 12,34 Nm (9.1 ft.lbs.) torque at max. power. The V6 is standard supplied according to the ATEX regulations. The power and speed are easily adjusted by pressure and air flow. These vane motors can be completed as desired with various accessories such as brakes, (control) valves and gearboxes.



A GLOBE Silencer is necessary for optimal reach of maximum power. Not installing a GLOBE Silencer will increase the risk of hearing damage, motor malfunctions or loss of power. It is also essential that an FRL unit is incorporated into the air-line to prevent motor malfunctions. Our silencers and FRL units are designed specifically for our motors to ensure maximum service life. Silencer is supplied with motor.

Versions of the V6 Vane Air Motor

Standard



Max. power	5.2 H.P. / 3,9 KW
Torque at max. power	9.1 ft.lbs. / 12,3 Nm
Min. starting torque	6.3 ft.lbs. / 8,54 Nm
Max. speed of rotation	3000 rpm
Mounting options	Hub / Flange / Feet / IEC

Non Lubricated



Max. power	3.7 H.P. / 2,7 KW
Torque at max. power	8.55 ft.lbs. / 11,6 Nm
Min. starting torque	5.7 ft.lbs. / 7.7 Nm
Max. speed of rotation	2250 rpm
Mounting options	Hub / Flange / Feet / IEC

Stainless Steel



Max. power	5.2 H.P. / 3,9 KW
Torque at max. power	9.1 ft.lbs. / 12,3 Nm
Min. starting torque	6.3 ft.lbs. / 8,54 Nm
Max. speed of rotation	3000 rpm
Mounting options	Hub / Flange / Feet / IEC

Which version do I need?

Our V6 Vane Air Motors are available as standard type, non lubricated or with a stainless steel housing. Our non lubricated vane air motors can run without lubrication under certain operating conditions. This makes them suitable for hygienic applications while saving on installation and annual running costs by not having to check oil levels.

Vane motors with stainless steel housing are widely used in the food, medical, pharmaceutical and chemical industries because of the hygienic aspect. They can be easily cleaned to keep your working environment sterile.

Geared vane air motor

Although our air motors can be adjusted over a wide range of speed and torque, the output characteristics may not always be suitable for the application. For lower speed applications, a gearbox can be coupled directly to the air motor. GLOBE Airmotors has a wide range of gear units available.

Dimensions V6

- » Maximum temperature for ATEX applications
-20°C to +60°C (-4°F to +140°F)
- » Maximum temperature for non-ATEX applications
-20°C to +80°C (-4°F to +176°F)

- » Silencer supplied with motor
- » Max. Overhung Force on shaft 300 N (70 lbf.)
- » Axial loads should be kept to a minimum

VS6C (IEC80 B5 Configuration)

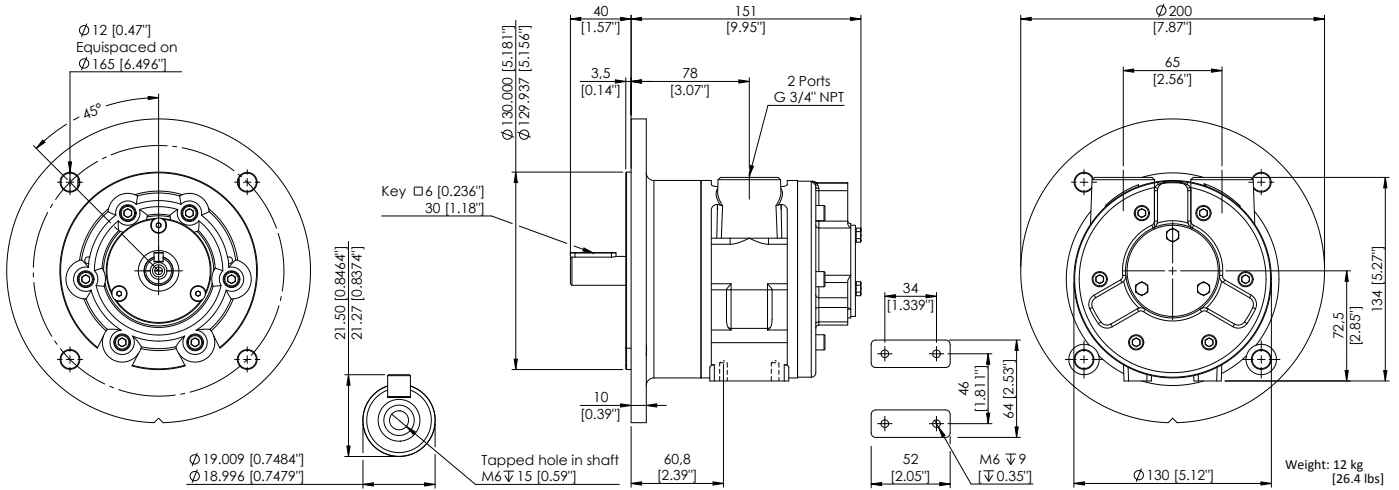

» Also available with IEC71 B5

VA6J&X

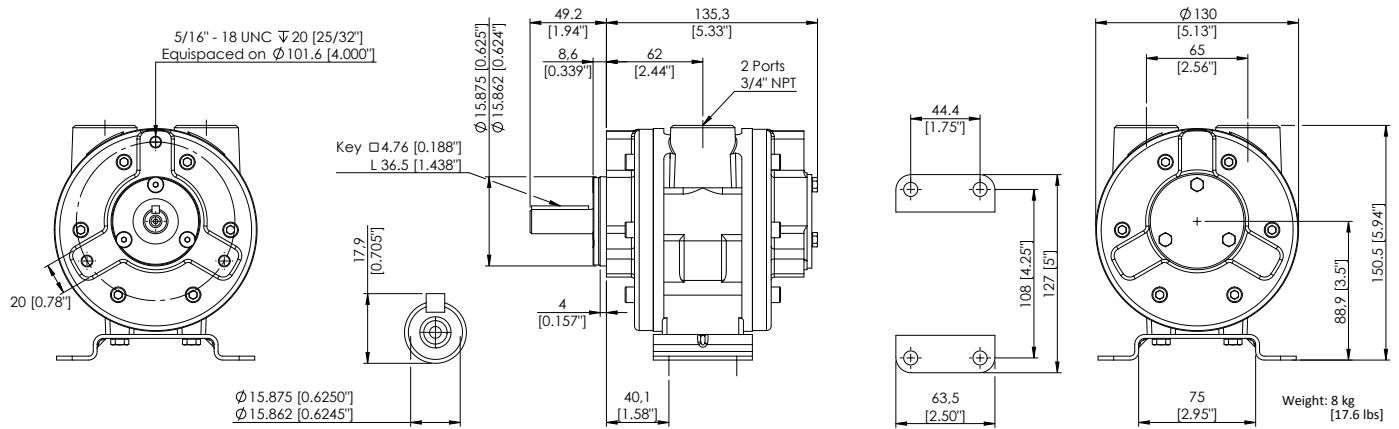

*Foot supplied loose with motor

VA6C (NEMA 56C Configuration)

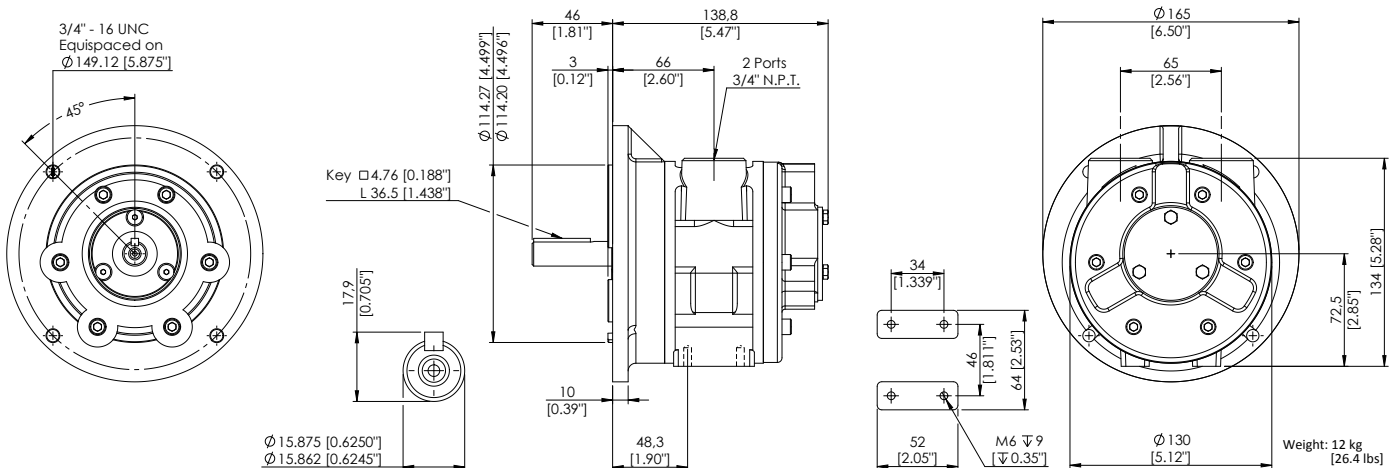

Performance V6 / V6-INOX

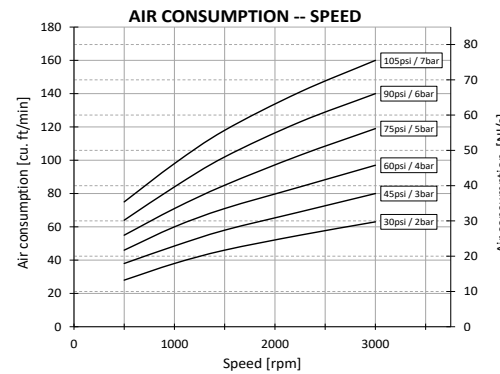
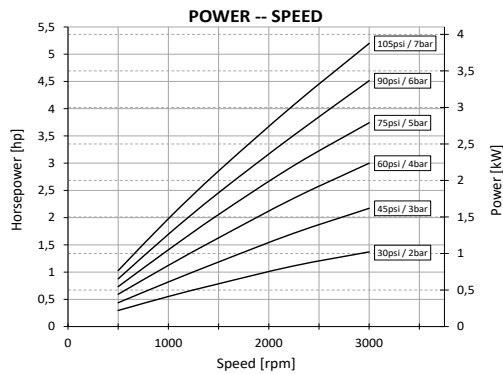
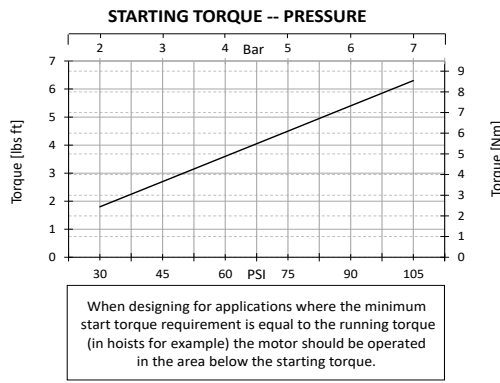
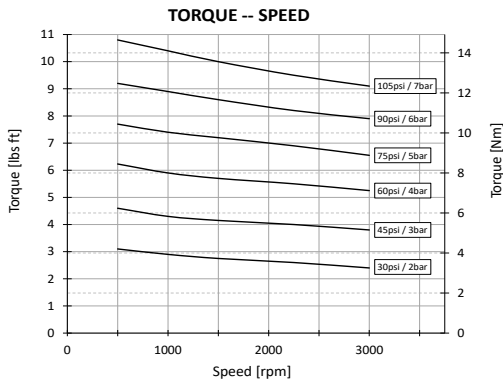

- » Silencer supplied with motor.
- » Motor is reversible.
- » Maximum temperature for ATEX applications: -20°C to +60°C (-4°F to +140°F)
- » Maximum temperature for non-ATEX applications: -20°C to +80°C (-4°F to +176°F)

Air supply lubrication and filtration:

Use 64 micron filtration or better. Choose a lubricator suitable for the flow required. Prior to initial startup, inject oil into the inlet port.

- Lubricator drop rate 5-6 drop / minute continuous operations
- Lubricator drop rate 10-12 drop / minute intermittent operation.

Maximum speed 3000 rpm

Life time depends highly on operational speed and air pressure.

Performance V6-Non Lubricated

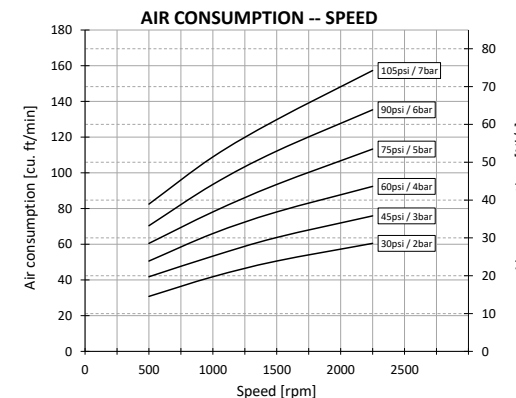
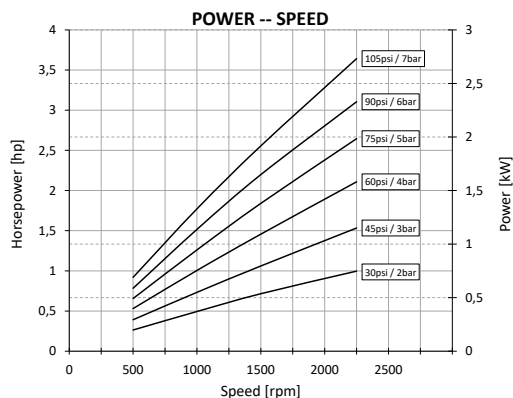
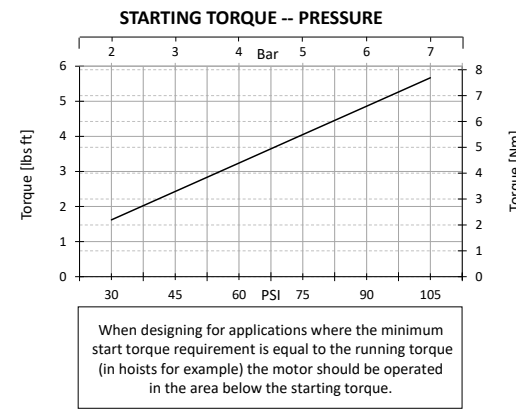
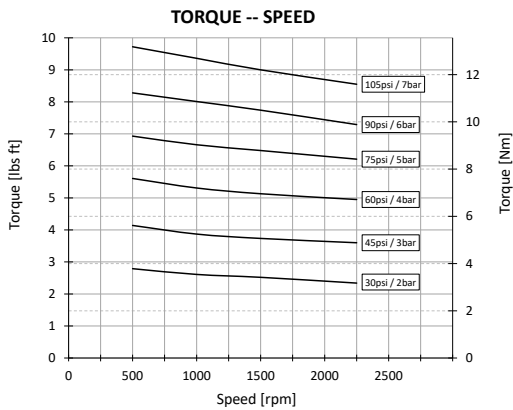

- » Silencer supplied with motor.
- » Motor is reversible.
- » Maximum temperature for ATEX applications: -20°C to +60°C (-4°F to +140°F)
- » Maximum temperature for non-ATEX applications: -20°C to +80°C (-4°F to +176°F)

Air quality and filtration:

Use 5 micron filtration. The air has to be dry to prevent corrosion inside the motor when it is not in use. Advisable is to use an air dryer with set point of 20 degrees Celsius below lowest ambient temperature.

Maximum speed 2250 rpm

Continuous speed 1500 rpm

Life time depends highly on operational speed and air pressure. Continuous duty is best suited to non lubricated operation. Moisture in the air can cause corrosion problems during rest periods.

Spare Parts VA6J&X

Item	Part No.	Description	Qty	Kit No.
1	760-001	Body NPT	1	
2	760-003	Front plate	1	
3	760-002	Back plate	1	
4	760-062	Gasket		769-910 / 769-915
5	760-911	Rotor	1	
6	760-006	Ejection ring	2	
7	760-005	Rotor blade	4	769-910 / 769-915
8	760-008	Cover plate	1	
9	760-009	Gasket	1	769-910 / 769-915
10	808-052	Shaft seal	1	769-910 / 769-915
11	760-007	Seal housing	1	
12	808-031	O-ring	1	769-910 / 769-915
13	804-052	Circlip	1	769-910 / 769-915
14	806-024	Dowel pin	4	
15	807-028	Bearing	1	
16	807-025	Bearing	1	
18	811-020	Key	1	
19	760-023	Foot (VA6J only)	1	
21	809-009	Screw	12	
23	805-006	Screw	3	
24		Screw	3	
25	802-012	Screw (VA6J only)	4	
	769-910	V6 Service Kit		
	769-915	V6-NL Service Kit		

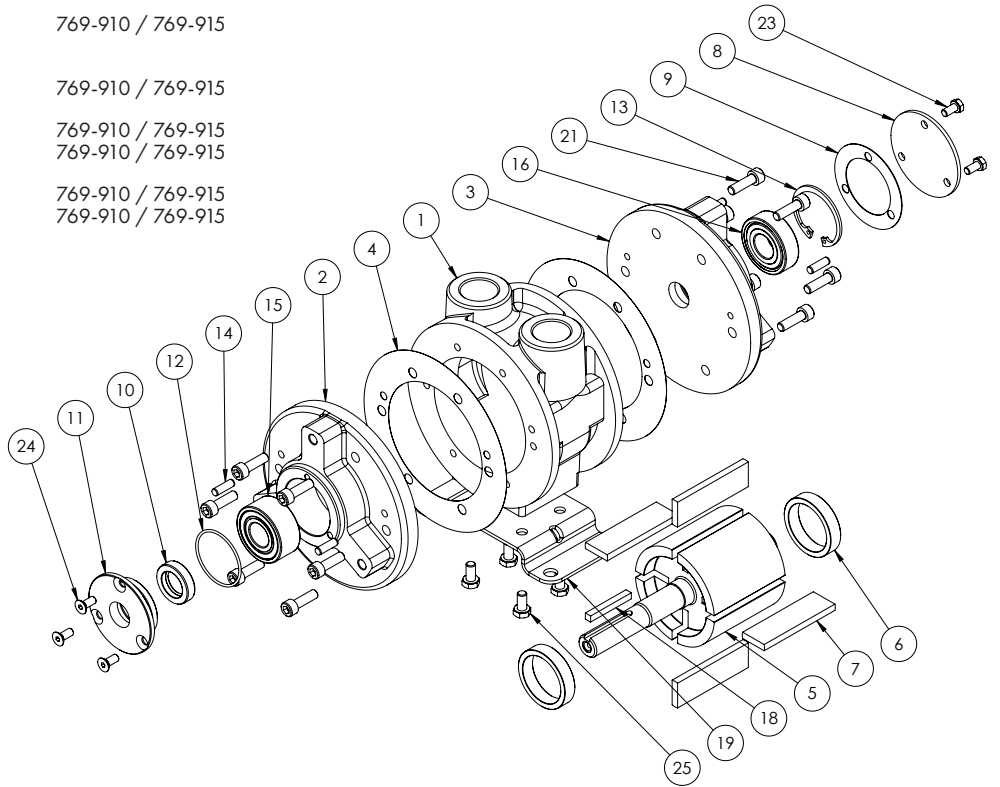

Spare Parts VA6C / VS6C

Item	Part No.	Description	Qty	Kit No.
1	760-001	Body NPT	1	
1	760-101	Body BSP (VS6C)	1	
2	760-018	Front plate	1	
2	760-036	Front plate (VS6C)	1	
3	760-002	Back plate	1	
4	760-062	Gasket		769-910 / 769-915
5	760-911	Rotor	1	
5	760-921	Rotor (VS6C)	1	
6	760-006	Ejection ring	2	
7	760-005	Rotor blade	4	769-910 / 769-915
8	760-008	Cover plate	1	
9	760-009	Gasket	1	769-910 / 769-915
10	808-052	Shaft seal	1	769-910 / 769-915
10	808-057	Shaft seal (VS6C)	1	769-910 / 769-915
11	760-017	Seal housing	1	
11	780-007	Seal housing (VS6C)	1	
12	808-031	O-ring	1	769-910 / 769-915
12	808-030	O-ring (VS6C)	1	769-910 / 769-915
13	804-052	Circlip	1	769-910 / 769-915
14	806-024	Dowel pin	4	
15	807-025	Bearing	1	
15	807-026	Bearing (VS6C)	1	
16	807-028	Bearing	1	
16	807-025	Bearing (VS6C)	1	
18	811-020	Key	1	
18	811-001	Key (VS6C)	1	
21	809-007	Screw	6	
22	809-009	Screw	6	
23	805-006	Screw	3	
24		Screw	3	
	769-910	V6 Service Kit		
	769-915	V6-NL Service Kit		

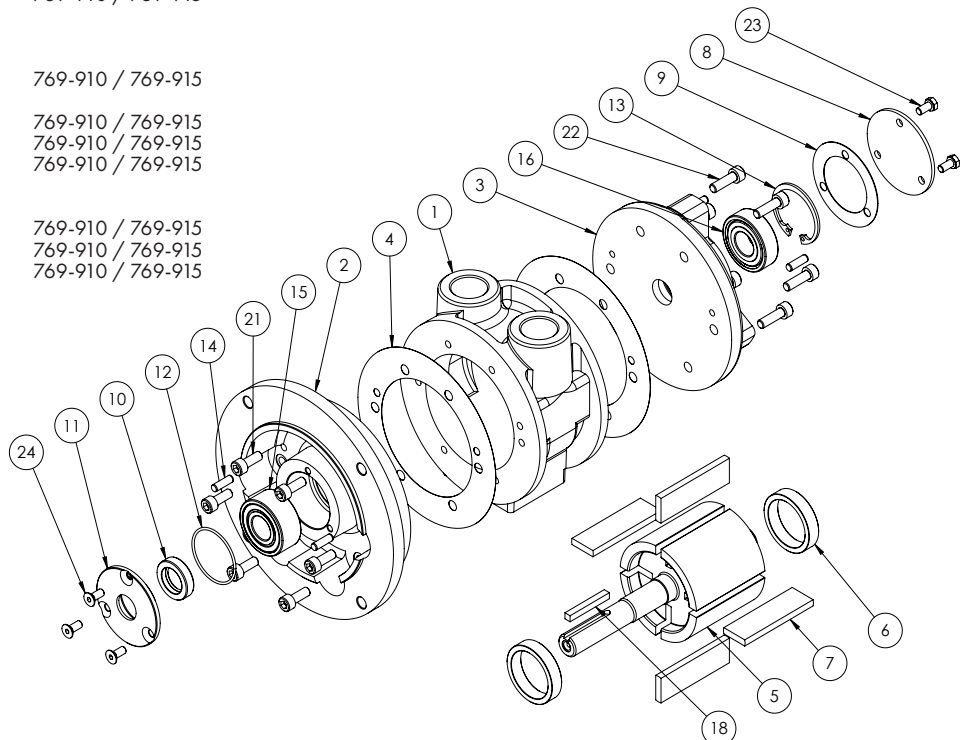

V8 Vane Air Motor

Why buy the GLOBE V8 Vane Air Motor

Our V8 Vane Air Motors have a maximum power range of 5,6 kW (7.55 HP) with 17,7 Nm (13.05 ft.lbs.) torque at max. power. The V8 is standard supplied according to the ATEX regulations. The power and speed are easily adjusted by pressure and air flow. These vane motors can be completed as desired with various accessories such as brakes, (control) valves and gearboxes.



A GLOBE Silencer is necessary for optimal reach of maximum power. Not installing a GLOBE Silencer will increase the risk of hearing damage, motor malfunctions or loss of power. It is also essential that an FRL unit is incorporated into the air-line to prevent motor malfunctions. Our silencers and FRL units are designed specifically for our motors to ensure maximum service life. Silencer is supplied with motor.

Versions of the V8 Vane Air Motor

Standard



Max. power	7.55 H.P. / 5,6 KW
Torque at max. power	13.6 ft.lbs. / 18,4 Nm
Min. starting torque	12.6 ft.lbs. / 17,1 Nm
Max. speed of rotation	3000 rpm
Mounting options	Hub / Flange / Feet / IEC

Non Lubricated



Max. power	5.6 H.P. / 4,17 KW
Torque at max. power	13,05 ft.lbs. / 17.7 Nm
Min. starting torque	11.34 ft.lbs. / 15,4 Nm
Max. speed of rotation	2250 rpm
Mounting options	Hub / Flange / Feet / IEC

Stainless Steel



Max. power	7.55 H.P. / 5,6 KW
Torque at max. power	13.6 ft.lbs. / 18,4 Nm
Min. starting torque	12.6 ft.lbs. / 17,1 Nm
Max. speed of rotation	3000 rpm
Mounting options	Hub / Flange / Feet / IEC

Which version do I need?

Our V8 Vane Air Motors are available as standard type, non lubricated or with a stainless steel housing. Our non lubricated vane air motors can run without lubrication under certain operating conditions. This makes them suitable for hygienic applications while saving on installation and annual running costs by not having to check oil levels.

Vane motors with stainless steel housing are widely used in the food, medical, pharmaceutical and chemical industries because of the hygienic aspect. They can be easily cleaned to keep your working environment sterile.

Geared vane air motor

Although our air motors can be adjusted over a wide range of speed and torque, the output characteristics may not always be suitable for the application. For lower speed applications, a gearbox can be coupled directly to the air motor. GLOBE Airmotors has a wide range of gear units available.

Dimensions V8

- » Maximum temperature for ATEX applications
-20°C to +60°C (-4°F to +140°F)
- » Maximum temperature for non-ATEX applications
-20°C to +80°C (-4°F to +176°F)

- » Silencer supplied with motor
- » Max. Overhung Force on shaft 620 N (140 lbf.)
- » Axial loads should be kept to a minimum

VS8C (IEC90 B5 Configuration)

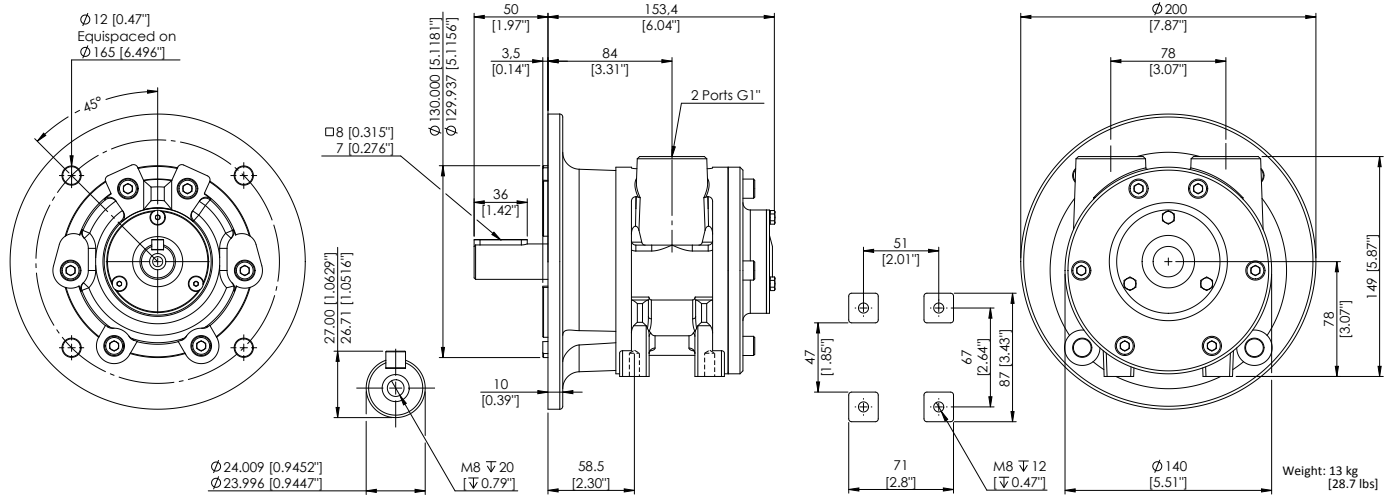

VA8J&X

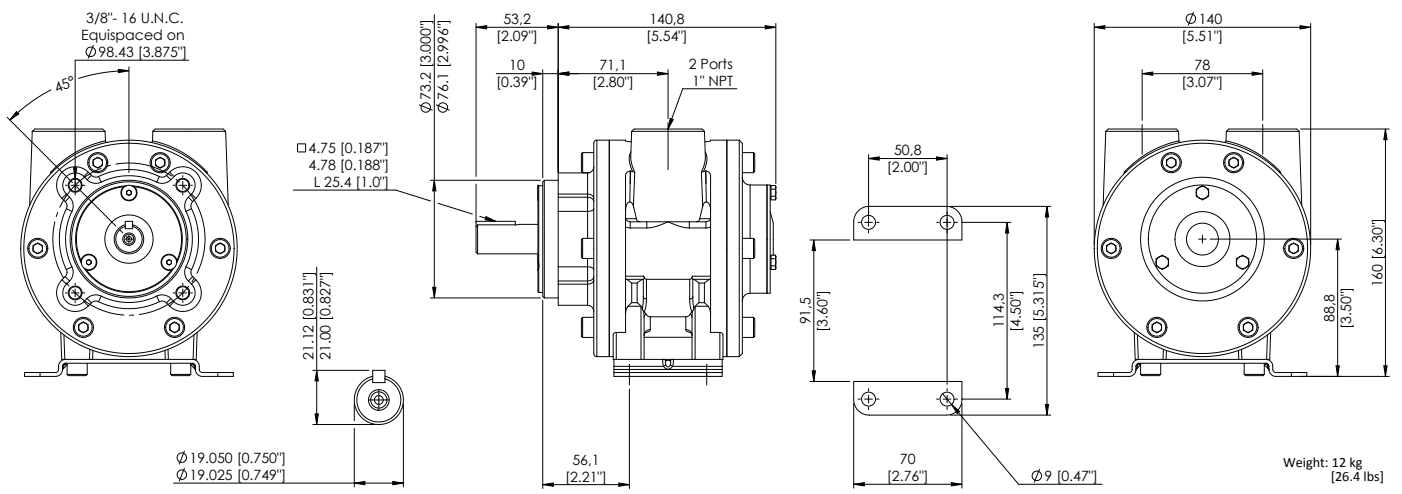

*Foot supplied loose with motor

VA8C (NEMA 145 TC Configuration)

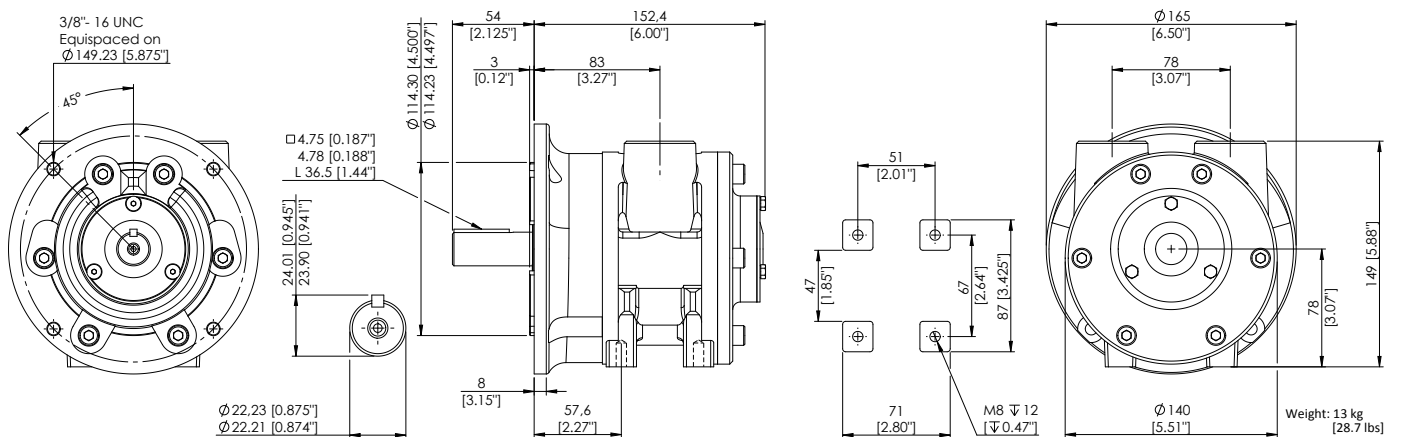

V8

Performance V8 / V8-INOX

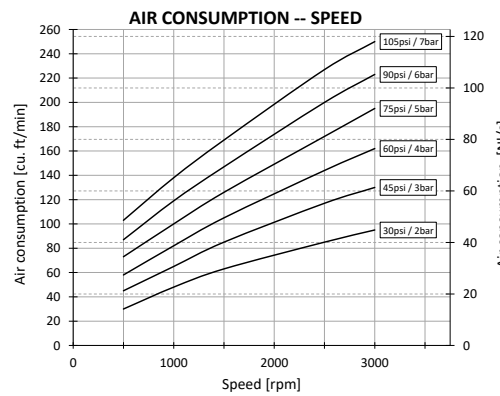
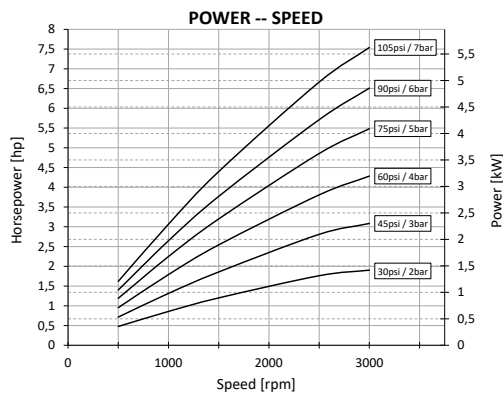
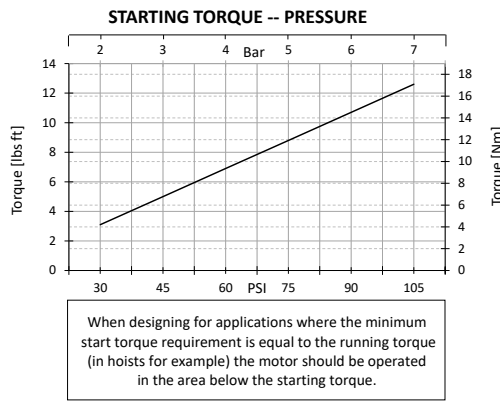
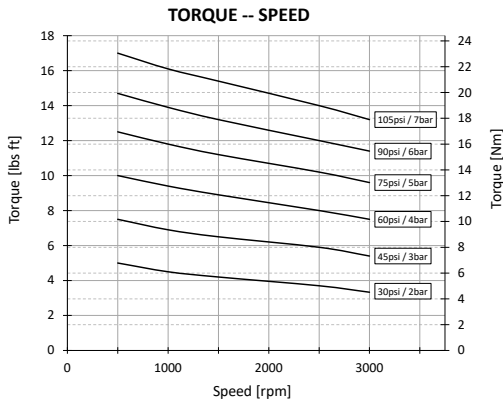

- » Silencer supplied with motor.
- » Motor is reversible.
- » Maximum temperature for ATEX applications: -20°C to +60°C (-4°F to +140°F)
- » Maximum temperature for non-ATEX applications: -20°C to +80°C (-4°F to +176°F)

Airsupply lubrication and filtration:

Use 64 micron filtration or better. Choose a lubricator suitable for the flow required. Prior to initial startup, inject oil into the inlet port.

Lubricator drop rate 6-7 drop / minute continuous operations
Lubricator drop rate 12-15 drop / minute intermittent operation.

Maximum speed 3000 rpm

Life time depends highly on operational speed and air pressure.

Performance V8-Non Lubricated

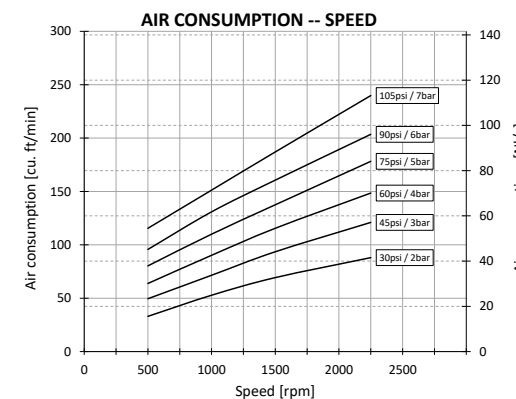
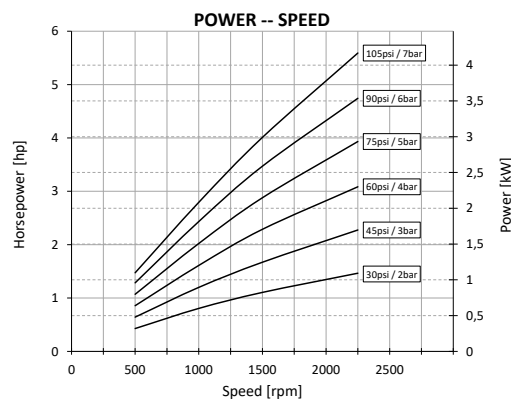
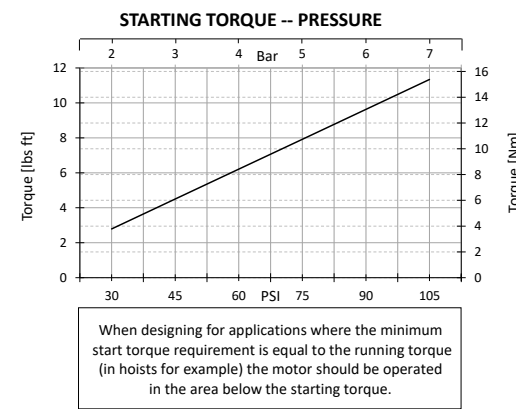
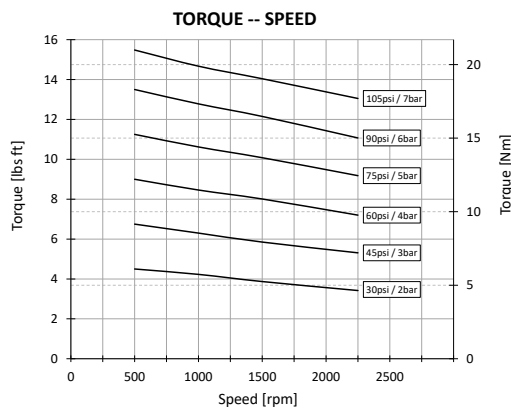

- » Silencer supplied with motor.
- » Motor is reversible.
- » Maximum temperature for ATEX applications: -20°C to +60°C (-4°F to +140°F)
- » Maximum temperature for non-ATEX applications: -20°C to +80°C (-4°F to +176°F)

Air quality and filtration:

Use 5 micron filtration. The air has to be dry to prevent corrosion inside the motor when it is not in use. Advisable is to use an air dryer with set point of 20 degrees Celsius below lowest ambient temperature.

Maximum speed 2250 rpm

Continuous speed 1500 rpm

Life time depends highly on operational speed and air pressure. Continuous duty is best suited to non lubricated operation. Moisture in the air can cause corrosion problems during rest periods.

Spare Parts VA8J&X

Item	Part No.	Description	Qty	Kit No.
1	780-001	Body NPT	1	
2	780-003	Front plate	1	
3	780-002	Back plate	1	
4	780-062	Gasket	1	789-910 / 789-915
5	780-911	Rotor	1	
6	780-006	Ejection ring	2	
7	780-005	Rotor blade	4	789-910 / 789-915
8	740-008	Cover plate	1	
9	808-030	O-ring	2	789-910 / 789-915
10	808-057	Shaft seal	1	789-910 / 789-915
11	780-007	Seal housing	1	
14	806-024	Dowel pin	4	
15	807-036	Bearing	1	
16	807-026	Bearing	1	
18	811-020	Key	1	
19	780-023	Foot (VA8J only)	1	
21	802-032	Screw	12	
23	802-001	Screw	3	
24		Screw	3	
25	809-026	Screw (VA8J only)	4	
	789-910	V8 Service Kit		
	789-915	V8-NL Service Kit		

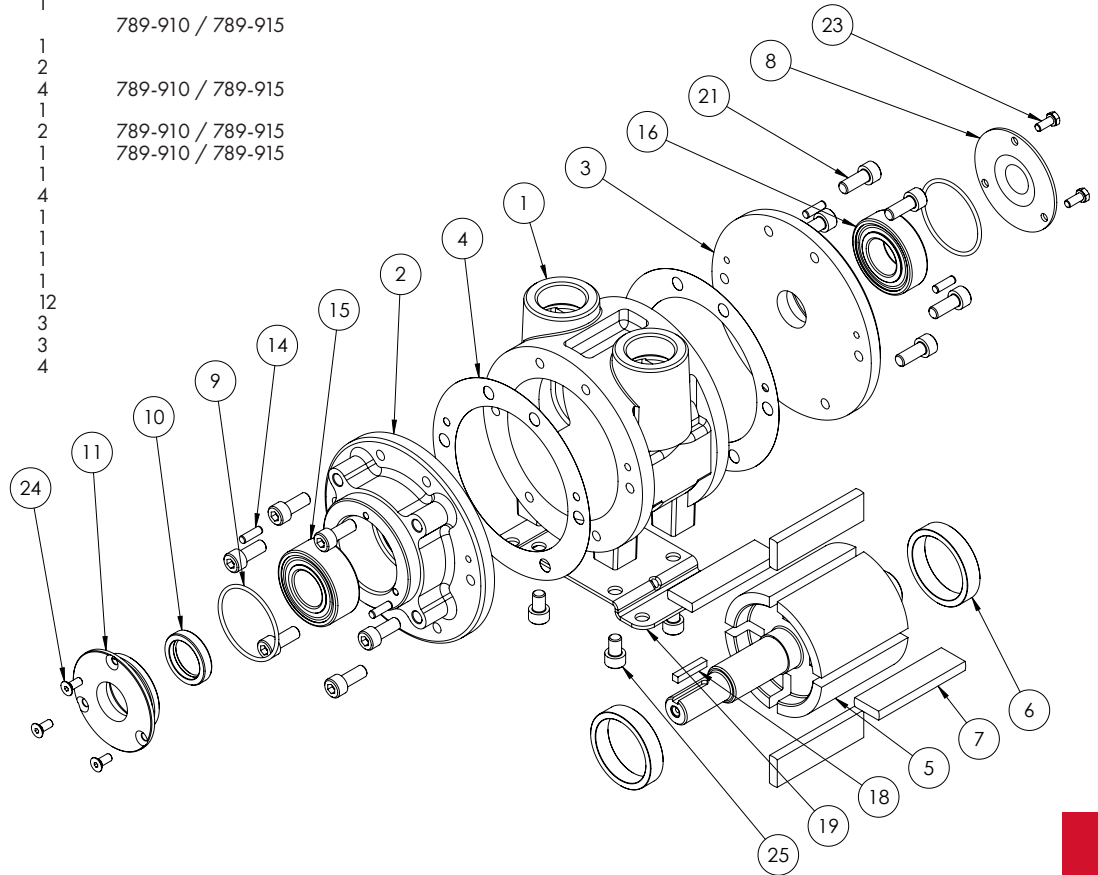

Spare Parts VA8C & VS8C

Item	Part No.	Description	Qty	Kit No.
1	780-001	Body NPT	1	
1	780-101	Body BSP (VS8C)	1	
2	780-018	Front plate	1	
2	780-036	Front plate (VS8C)	1	
3	780-002	Back plate	1	
4	780-062	Gasket	1	789-910 / 789-915
5	780-910	Rotor	1	
5	780-922	Rotor (VS8C)	1	
6	780-006	Ejection ring	2	
7	780-005	Rotor blade	4	789-910 / 789-915
8	740-008	Cover plate	1	
9	808-030	O-ring	2	789-910 / 789-915
10	808-057	Shaft seal	1	789-910 / 789-915
11	780-007	Seal housing	1	
14	806-024	Dowel pin	4	
15	807-036	Bearing	1	
16	807-026	Bearing	1	
18	811-020	Key	1	
18	811-042	Key (VS8C)	1	
21	809-030	Screw	6	
22	802-032	Screw	6	
23	802-001	Screw	3	
24		Screw	3	
	789-910	V8 Service Kit		
	789-915	V8-NL Service Kit		

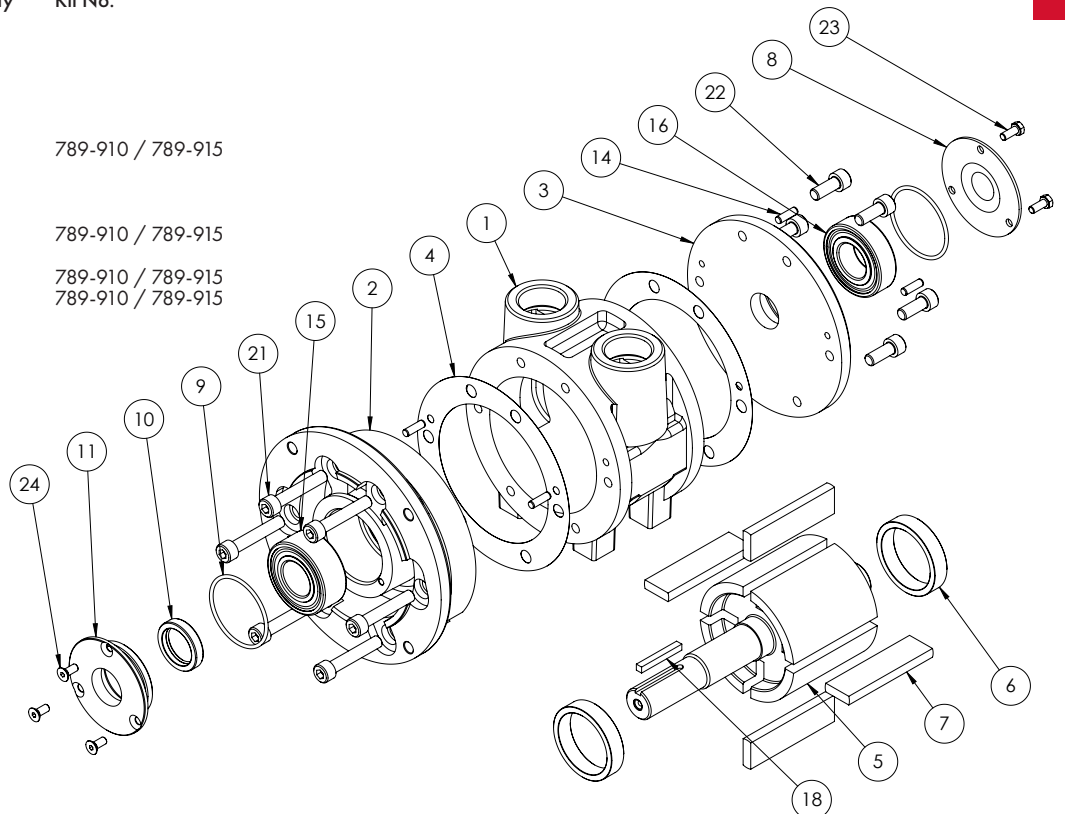

V10 Vane Air Motor

Why buy the GLOBE V10 Vane Air Motor

Our V10 Vane Air Motors have a maximum power range of 10,2 kW (13.7 HP) with 40.7 Nm (30 ft.lbs.) torque at max. power. The V10 is standard supplied according to the ATEX regulations. The power and speed are easily adjusted by pressure and air flow. These vane motors can be completed as desired with various accessories such as brakes, (control) valves and gearboxes.



A GLOBE Silencer is necessary for optimal reach of maximum power. Not installing a GLOBE Silencer will increase the risk of hearing damage, motor malfunctions or loss of power. It is also essential that an FRL unit is incorporated into the air-line to prevent motor malfunctions. Our silencers and FRL units are designed specifically for our motors to ensure maximum service life. Silencer is supplied with motor.

Versions of the V10 Vane Air Motor

Standard



Max. power	13.7 H.P. / 10,2 KW
Torque at max. power	30 ft.lbs. / 40,7 Nm
Min. starting torque	27.5 ft.lbs. / 37,3 Nm
Max. speed of rotation	2400 rpm
Mounting options	Hub / Flange / Feet / IEC

Non Lubricated



Max. power	9.7 H.P. / 7,25 KW
Torque at max. power	28.4 ft.lbs. / 38,4 Nm
Min. starting torque	24.8 ft.lbs. / 33,6 Nm
Max. speed of rotation	1600 rpm
Mounting options	Hub / Flange / Feet / IEC

Stainless Steel



Max. power	13.7 H.P. / 10,2 KW
Torque at max. power	30 ft.lbs. / 40,7 Nm
Min. starting torque	27.5 ft.lbs. / 37,3 Nm
Max. speed of rotation	2400 rpm
Mounting options	Hub / Flange / Feet / IEC

Which version do I need?

Our V10 Vane Air Motors are available as standard type, non lubricated or with a stainless steel housing. Our non lubricated vane air motors can run without lubrication under certain operating conditions. This makes them suitable for hygienic applications while saving on installation and annual running costs by not having to check oil levels.

Vane motors with stainless steel housing are widely used in the food, medical, pharmaceutical and chemical industries because of the hygienic aspect. They can be easily cleaned to keep your working environment sterile.

Geared vane air motor

Although our air motors can be adjusted over a wide range of speed and torque, the output characteristics may not always be suitable for the application. For lower speed applications, a gearbox can be coupled directly to the air motor. GLOBE Airmotors has a wide range of gear units available.

Dimensions V10

- » Maximum temperature for ATEX applications
-20°C to +60°C (-4°F to +140°F)
- » Maximum temperature for non-ATEX applications
-20°C to +80°C (-4°F to +176°F)

- » Silencer supplied with motor
- » Max. Overhung Force on shaft 1750 N (400 lbf.)
- » Axial loads should be kept to a minimum

VS10C (IEC100 B5 Configuration)

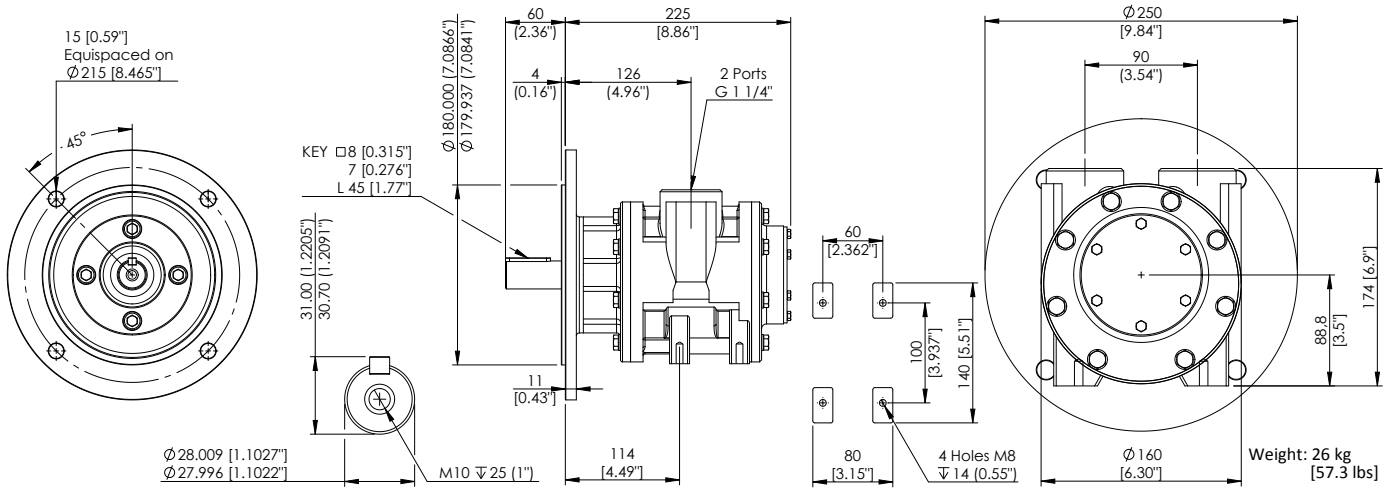

VA10J&X

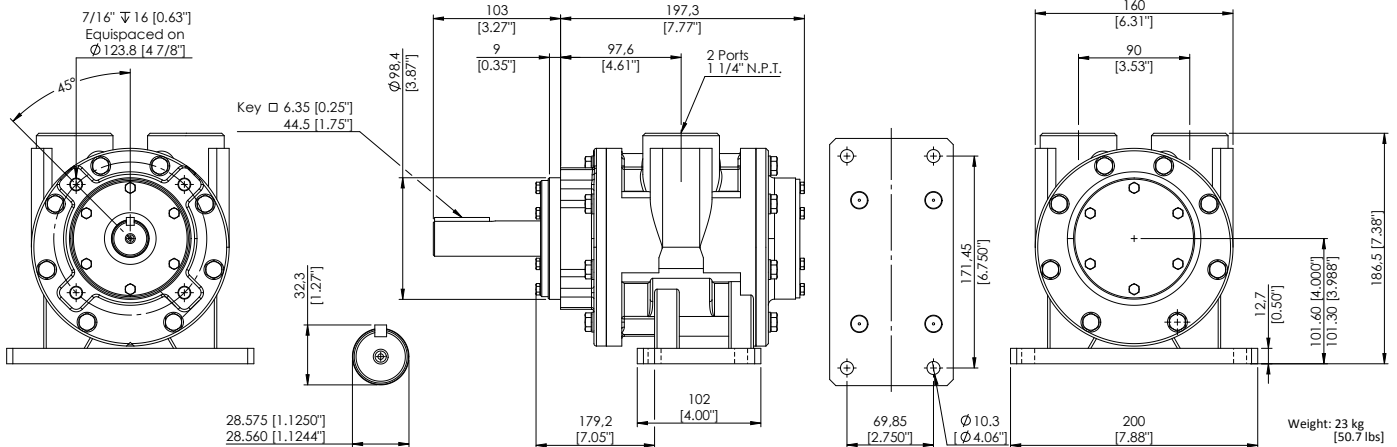

*Foot supplied loose with motor

VA10C (NEMA 145TC Configuration)

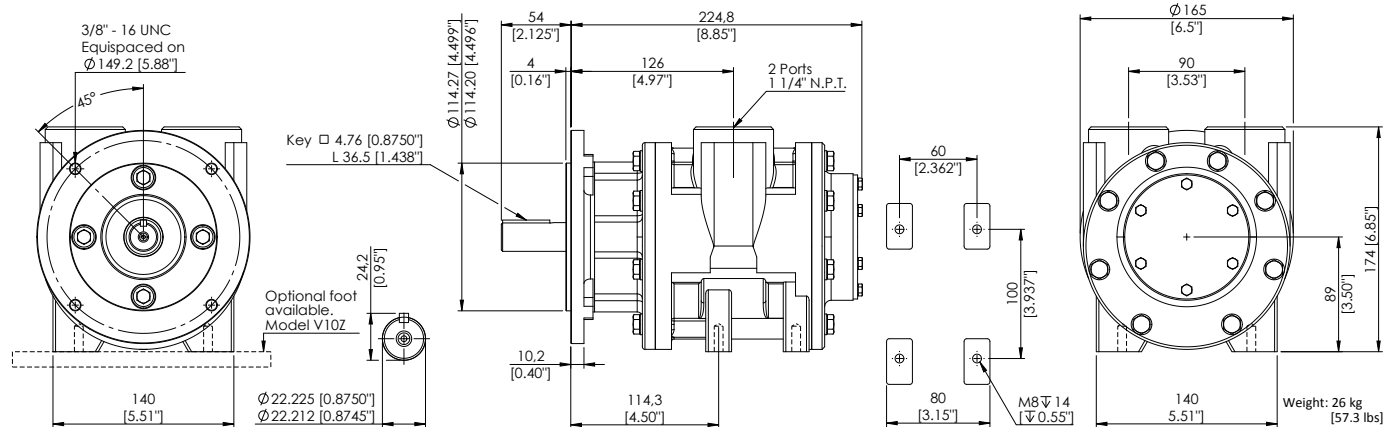

V10

Performance V10 / V10-INOX

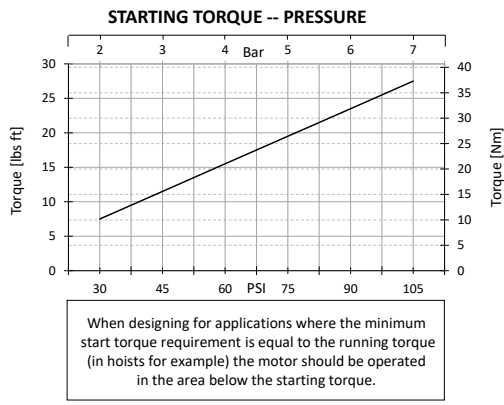
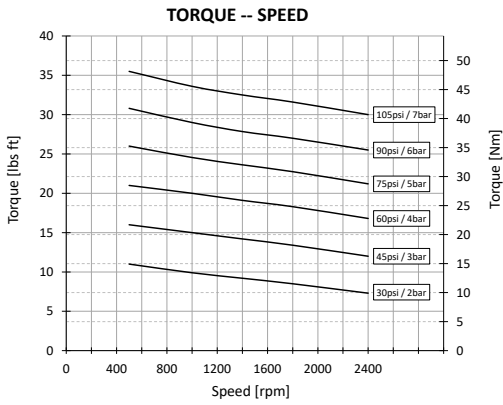

- » Silencer supplied with motor.
- » Motor is reversible.
- » Maximum temperature for ATEX applications: -20°C to +60°C (-4°F to +140°F)
- » Maximum temperature for non-ATEX applications: -20°C to +80°C (-4°F to +176°F)

Airsupply lubrication and filtration:

Use 64 micron filtration or better. Choose a lubricator suitable for the flow required. Prior to initial startup, inject oil into the inlet port.

Lubricator drop rate 7-8 drop / minute continuous operations
 Lubricator drop rate 14-16 drop / minute intermittent operation.

Maximum speed 2400 rpm

Life time depends highly on operational speed and air pressure.

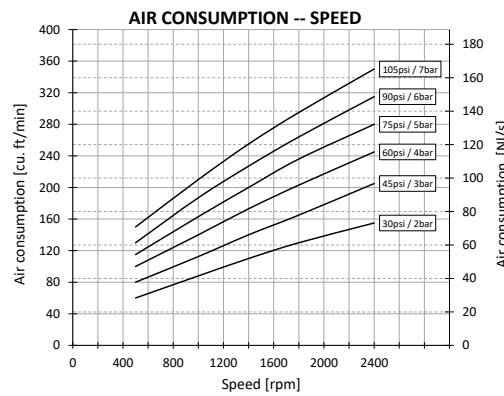
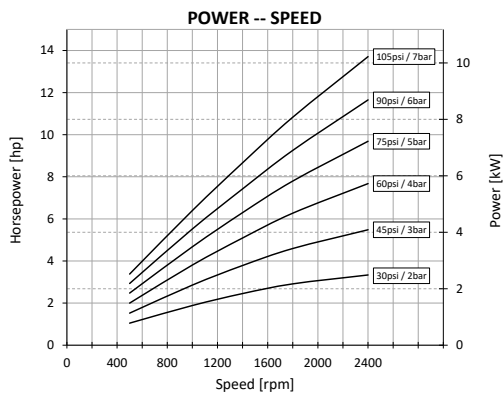

Performance V10-Non Lubricated

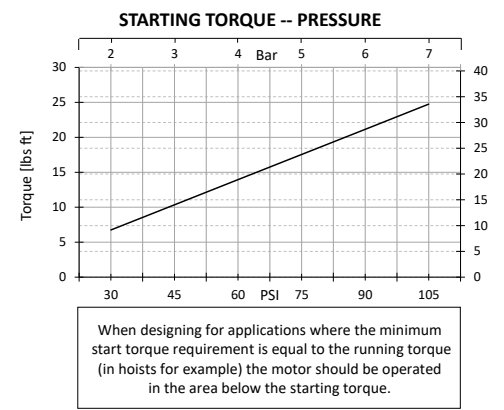
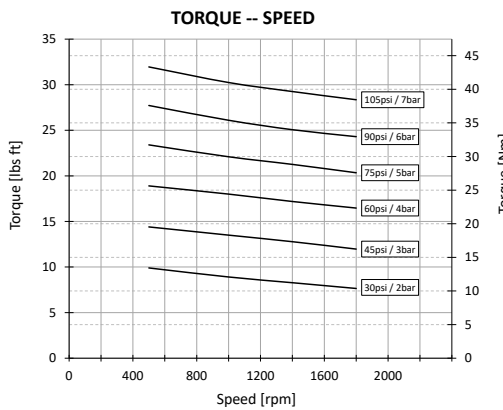

- » Silencer supplied with motor.
- » Motor is reversible.
- » Maximum temperature for ATEX applications: -20°C to +60°C (-4°F to +140°F)
- » Maximum temperature for non-ATEX applications: -20°C to +80°C (-4°F to +176°F)

Air quality and filtration:

Use 5 micron filtration. The air has to be dry to prevent corrosion inside the motor when it is not in use. Advisable is to use an air dryer with set point of 20 degrees Celsius below lowest ambient temperature.

Maximum speed 1800 rpm

Continuous speed 1200 rpm
 Life time depends highly on operational speed and air pressure. Continuous duty is best suited to non lubricated operation. Moisture in the air can cause corrosion problems during rest periods.

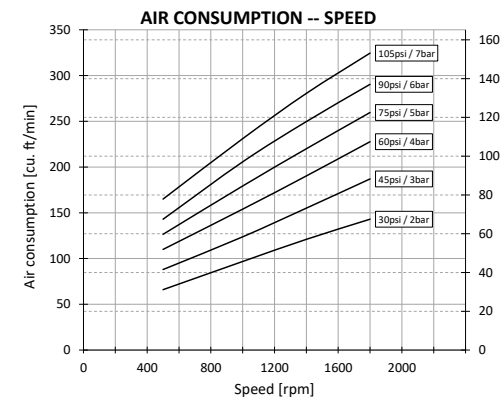
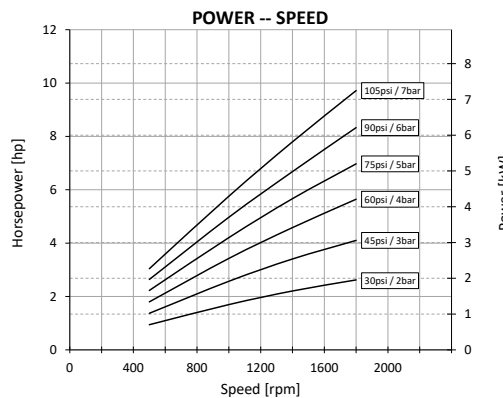

Spare Parts VA10J&X

Item	Part No.	Description	Qty	Kit No.
1	790-001	Body NPT	1	
2	790-003	Front plate	1	
3	790-002	Back plate	1	
4	790-062	Gasket	1	799-910 / 799-915
5	790-911	Rotor	1	
6	790-006	Ejection ring	2	
7	790-005	Rotor blade	6	799-910 / 799-915
8	790-008	Cover plate	1	
9	790-009	Gasket	1	799-910 / 799-915
10	808-058	Shaft seal	1	799-910 / 799-915
11	790-007	Seal housing	1	
12	808-038	O-ring	1	799-910 / 799-915
14	806-018	Dowel pin	4	
15	807-037	Bearing	1	
16	807-019	Bearing	1	
18	811-024	Key	1	
19	790-015	Foot (VA10J only)	1	
21	802-033	Screw	16	
23	802-007	Screw	12	
25	809-008	Screw (VA10J only)	4	
27	803-019	Washer	16	
	799-910	V10 Service Kit		
	799-915	V10-NL Service Kit		

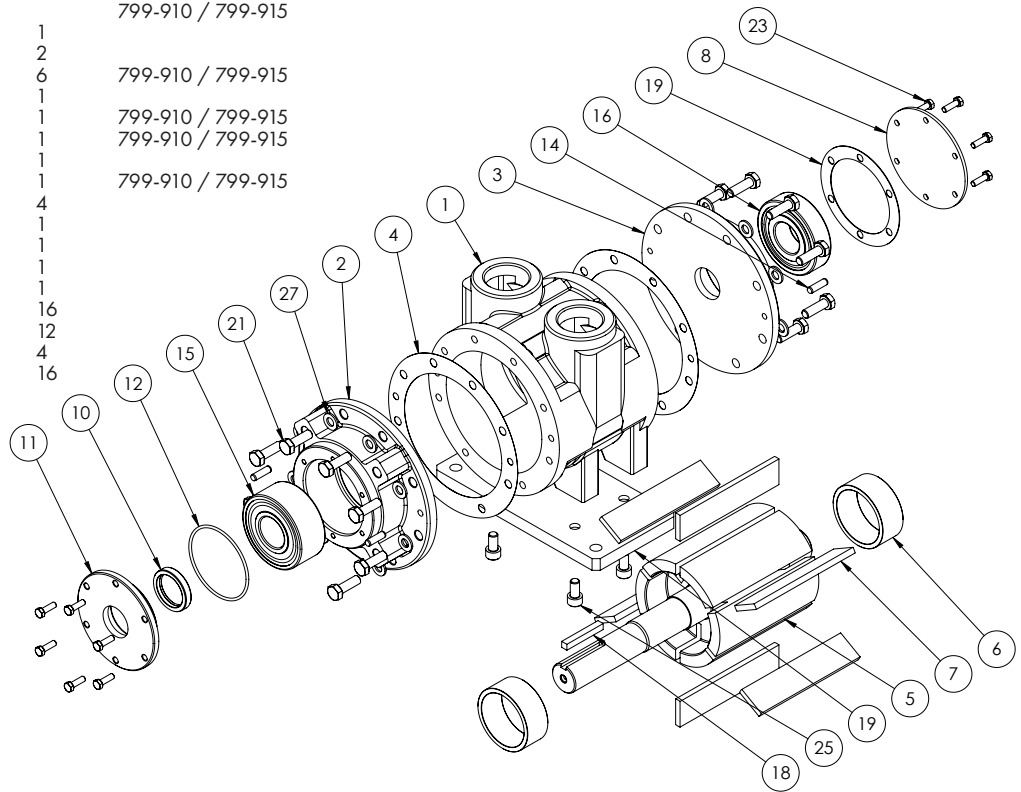

Spare Parts VA10C & VS10C

Item	Part No.	Description	Qty	Kit No.
1	790-001	Body NPT	1	
1	790-101	Body BSP (VS10C)	1	
2	790-026	Front plate	1	
3	790-002	Back plate	1	
4	790-062	Gasket	1	799-910 / 799-915
5	790-910	Rotor	1	
5	790-923	Rotor (VS10C)	1	
6	790-006	Ejection ring	2	
7	790-005	Rotor blade	6	799-910 / 799-915
8	790-008	Cover plate	1	
9	790-009	Gasket	1	799-910 / 799-915
10	808-058	Shaft seal	1	799-910 / 799-915
12	808-038	O-ring	1	799-910 / 799-915
14	806-018	Dowel pin	4	
15	807-019	Bearing	1	
15	807-037	Bearing (VS10C)	1	
16	807-037	Bearing	1	
16	807-019	Bearing (VS10C)	1	
17	790-018	Flange	1	
17	790-036	Flange (VS10C)	1	
18	811-020	Key	1	
18	811-033	Key (VS10C)	1	
21	802-033	Screw	16	
23	802-007	Screw	6	
26	809-019	Screw	4	
27	803-019	Washer	16	
	799-910	V10 Service Kit		
	799-915	V10-NL Service Kit		

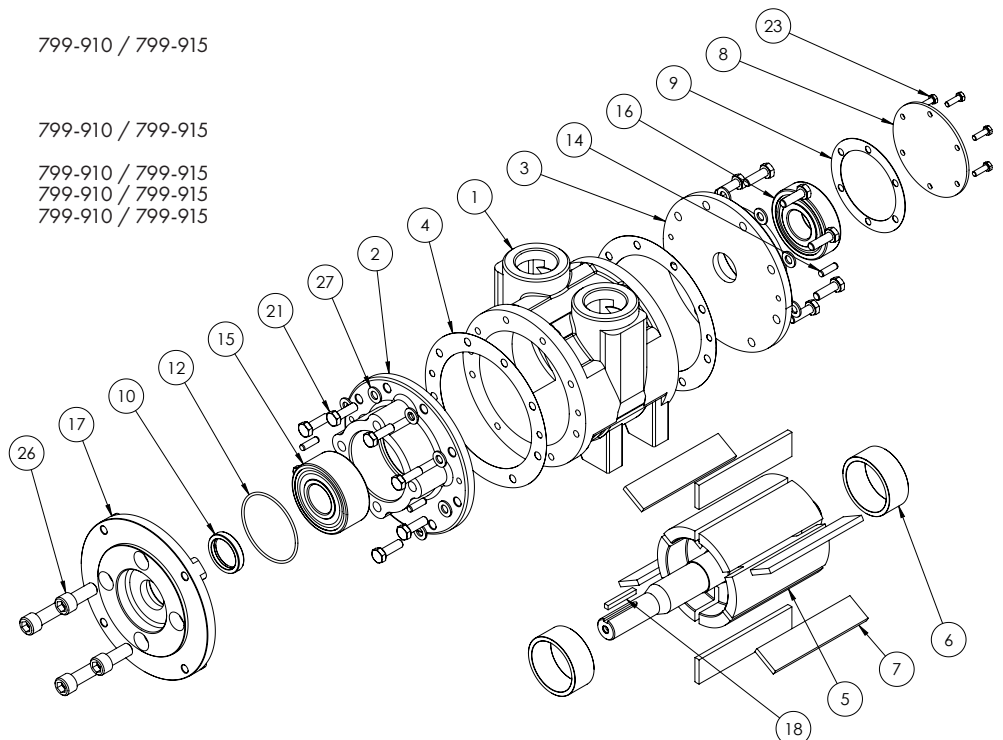

V10

V12 Vane Air Motor

Why buy the GLOBE V12 Vane Air Motor

Our V12 Vane Air Motors have a maximum power range of 14 kW (18.8 HP) with 74,6 Nm (55 ft.lbs.) torque at max. power. The V12 is standard supplied according to the ATEX regulations. The power and speed are easily adjusted by pressure and air flow. These vane motors can be completed as desired with various accessories such as brakes, (control) valves and gearboxes.



A GLOBE Silencer is necessary for optimal reach of maximum power. Not installing a GLOBE Silencer will increase the risk of hearing damage, motor malfunctions or loss of power. It is also essential that an FRL unit is incorporated into the air-line to prevent motor malfunctions. Our silencers and FRL units are designed specifically for our motors to ensure maximum service life. Silencer is supplied with motor.

Versions of the V12 Vane Air Motor

Standard



Max. power	18.8 H.P. / 14 KW
------------	-------------------

Torque at max. power	55 ft.lbs. / 74,6 Nm
----------------------	----------------------

Min. starting torque	54 ft.lbs. / 73,2 Nm
----------------------	----------------------

Max. speed of rotation	1800 rpm
------------------------	----------

Mounting options	Hub / Flange / Feet / IEC
------------------	---------------------------

Non Lubricated



Max. power	12.7 H.P. / 9,5 KW
------------	--------------------

Torque at max. power	49.5 ft.lbs. / 67 Nm
----------------------	----------------------

Min. starting torque	47.8 ft.lbs. / 64,8 Nm
----------------------	------------------------

Max. speed of rotation	1350 rpm
------------------------	----------

Mounting options	Hub / Flange / Feet / IEC
------------------	---------------------------

Stainless Steel



Max. power	19 H.P. / 14 KW
------------	-----------------

Torque at max. power	55.2 ft.lbs. / 75 Nm
----------------------	----------------------

Min. starting torque	75.1 ft.lbs. / 102 Nm
----------------------	-----------------------

Max. speed of rotation	1800 rpm
------------------------	----------

Mounting options	Hub / Flange / Feet / IEC
------------------	---------------------------

Which version do I need?

Our V12 Vane Air Motors are available as standard type, non lubricated or with a stainless steel housing. Our non lubricated vane air motors can run without lubrication under certain operating conditions. This makes them suitable for hygienic applications while saving on installation and annual running costs by not having to check oil levels.

Vane motors with stainless steel housing are widely used in the food, medical, pharmaceutical and chemical industries because of the hygienic aspect. They can be easily cleaned to keep your working environment sterile.

Geared vane air motor

Although our air motors can be adjusted over a wide range of speed and torque, the output characteristics may not always be suitable for the application. For lower speed applications, a gearbox can be coupled directly to the air motor. GLOBE Airmotors has a wide range of gear units available.

Dimensions V12

- » Maximum temperature for ATEX applications
-20°C to +60°C (-4°F to +140°F)
- » Maximum temperature for non-ATEX applications
-20°C to +80°C (-4°F to +176°F)

- » Silencer supplied with motor
- » Max. Overhung Force on shaft 400 N (90 lbf.)
- » Axial loads should be kept to a minimum

VS12C (IEC100 B5 Configuration)

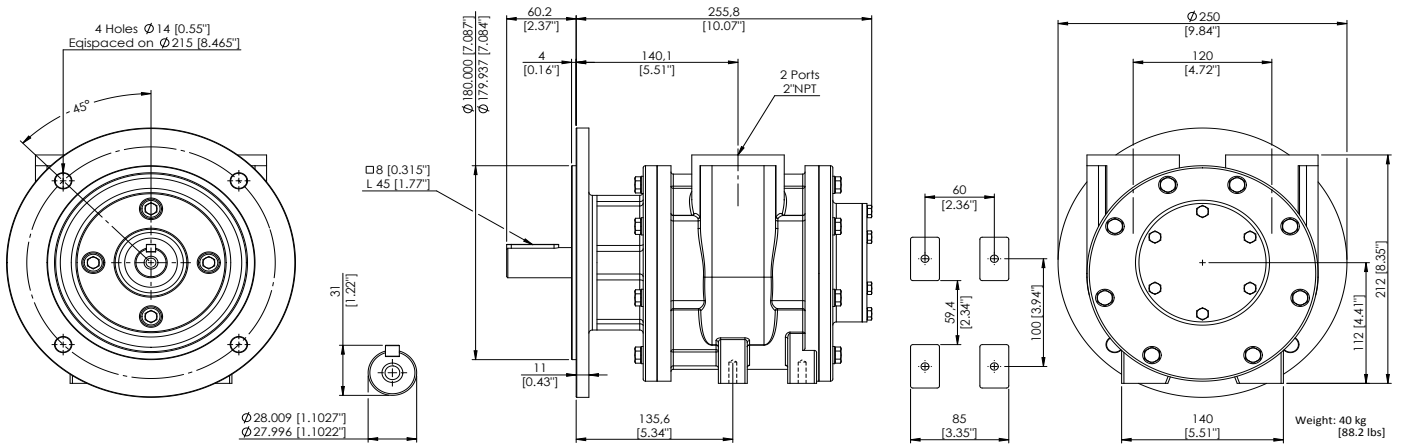

VA12C (NEMA 215TC Configuration)

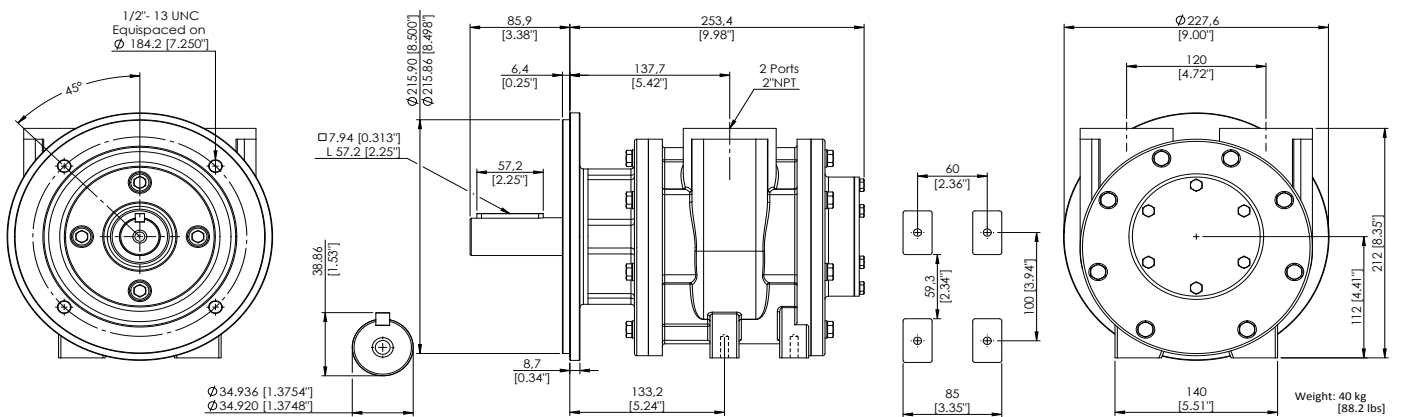

V12

Performance V12 / V12-INOX

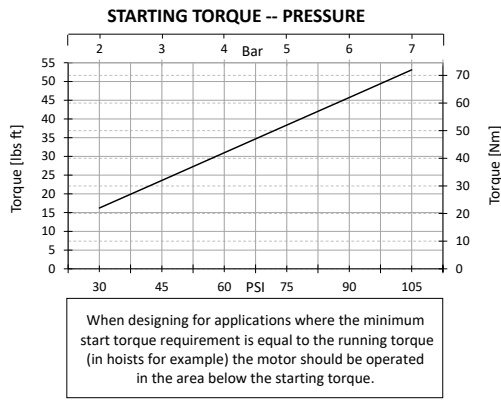
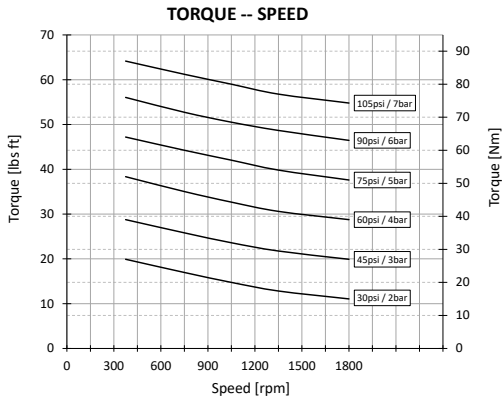

- » Silencer supplied with motor.
- » Motor is reversible.
- » Maximum temperature for ATEX applications: -20°C to +60°C (-4°F to +140°F)
- » Maximum temperature for non-ATEX applications: -20°C to +80°C (-4°F to +176°F)

Air supply lubrication and filtration:

Use 64 micron filtration or better. Choose a lubricator suitable for the flow required. Prior to initial startup, inject oil into the inlet port.

Lubricator drop rate 12-14 drop / minute continuous operations
 Lubricator drop rate 18-20 drop / minute intermittent operation.

Maximum speed 1800 rpm

Life time depends highly on operational speed and air pressure.

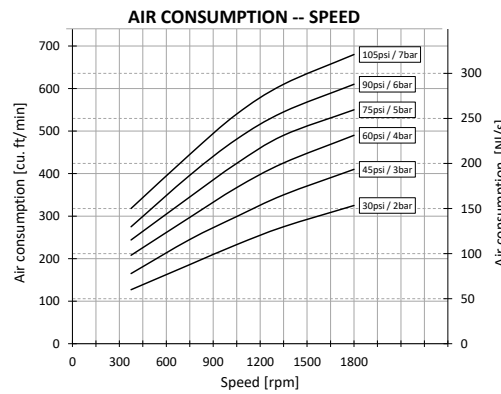
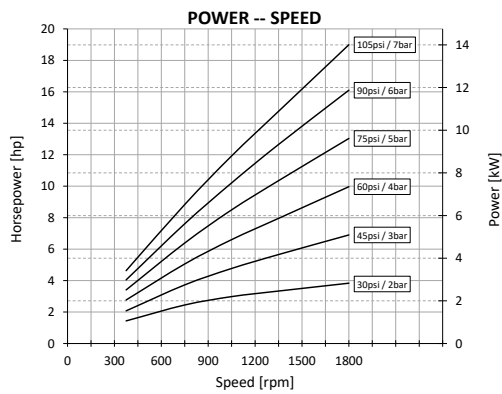

Performance V12-Non Lubricated

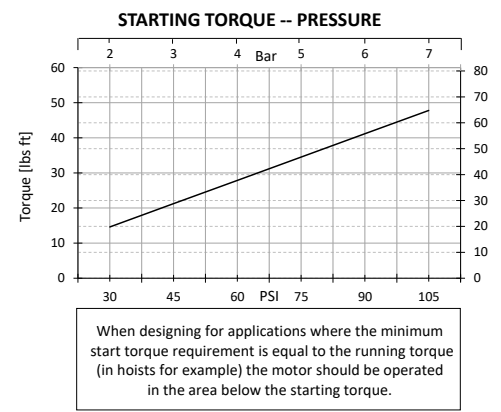
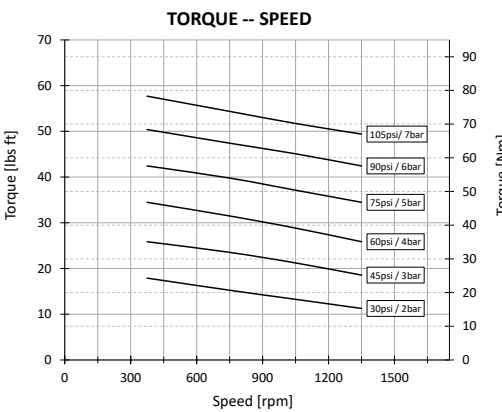

- » Silencer supplied with motor.
- » Motor is reversible.
- » Maximum temperature for ATEX applications: -20°C to +60°C (-4°F to +140°F)
- » Maximum temperature for non-ATEX applications: -20°C to +80°C (-4°F to +176°F)

Air quality and filtration:

Use 5 micron filtration. The air has to be dry to prevent corrosion inside the motor when it is not in use. Advisable is to use an air dryer with set point of 20 degrees Celsius below lowest ambient temperature.

Maximum speed 1350 rpm

Continuous speed 950 rpm

Life time depends highly on operational speed and air pressure. Continuous duty is best suited to non lubricated operation. Moisture in the air can cause corrosion problems during rest periods.

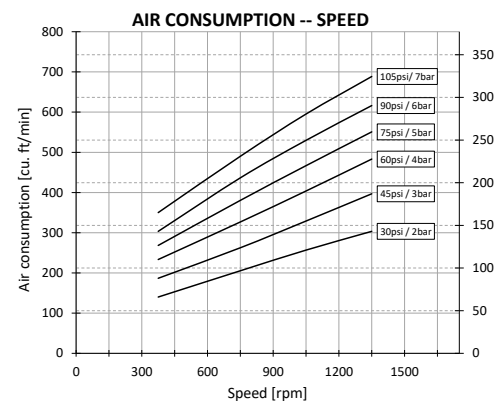
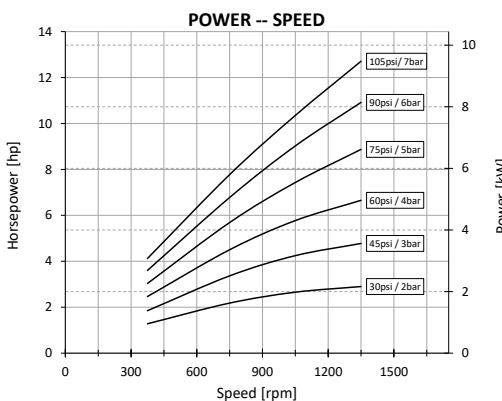

Spare Parts VS12C

Item	Part No.	Description	Qty	Kit No.
1	712-101	Body BSP	1	
2	712-026	Front plate	1	
3	712-002	Back plate	1	
4	712-062	Gasket	1	712-910 / 712-915
5	712-923	Rotor	1	
6	712-006	Ejection ring	2	
7	712-005	Rotor blade	6	712-910 / 712-915
8	712-008	Cover plate	1	
9	712-009	Gasket	1	712-910 / 712-915
10	808-063	Shaft seal	1	712-910 / 712-915
12	808-040	O-ring	1	712-910 / 712-915
14	806-018	Dowel pin	4	
15	807-039	Bearing	1	
16	807-029	Bearing	1	
17	712-036	Flange	1	
18	811-033	Key	1	
21	802-034	Screw	16	
23	802-011	Screw	6	
26	809-019	Screw	4	
27	803-019	Washer	16	
28	808-041	O-ring	1	712-910 / 712-915

712-910 V12 Service Kit
712-915 V12-NL Service Kit

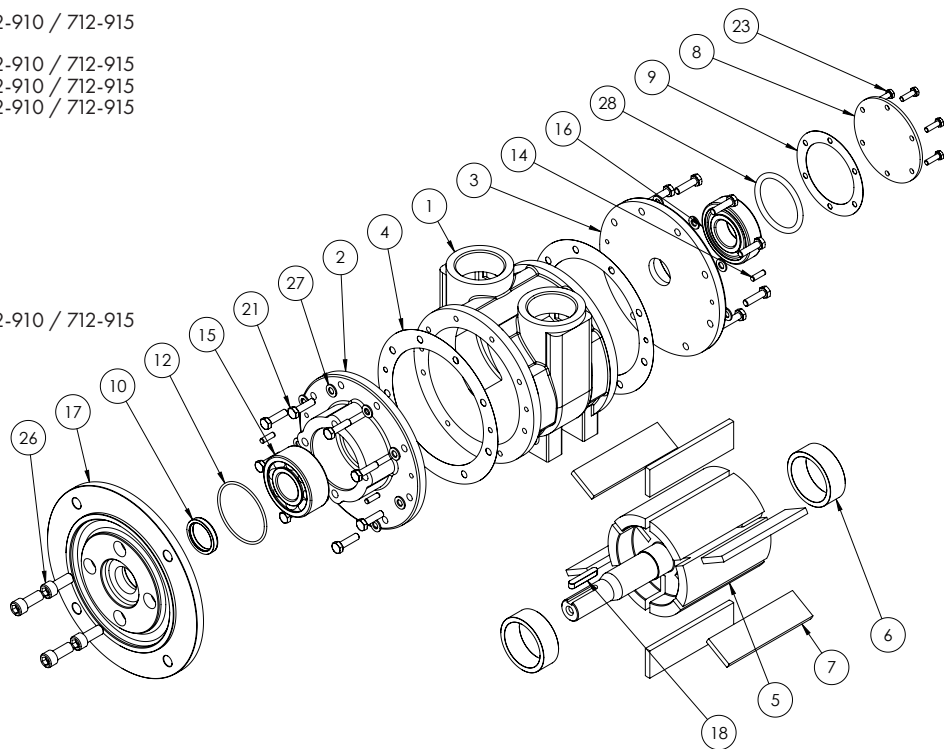

Spare Parts VA12C

Item	Part No.	Description	Qty	Kit No.
1	712-001	Body NPT	1	
2	712-026	Front plate	1	
3	712-002	Back plate	1	
4	712-062	Gasket	1	712-910 / 712-915
5	712-910	Rotor	1	
6	712-006	Ejection ring	2	
7	712-005	Rotor blade	6	712-910 / 712-915
8	712-008	Cover plate	1	
9	712-009	Gasket	1	712-910 / 712-915
10	808-063	Shaft seal	1	712-910 / 712-915
12	808-040	O-ring	1	712-910 / 712-915
14	806-018	Dowel pin	4	
15	807-039	Bearing	1	
16	807-029	Bearing	1	
17	712-018	Flange	1	
18	811-026	Key	1	
21	802-034	Screw	16	
23	802-011	Screw	6	
26	809-019	Screw	4	
27	803-019	Washer	16	
28	808-041	O-ring	1	712-910 / 712-915

712-910 V12 Service Kit
712-915 V12-NL Service Kit

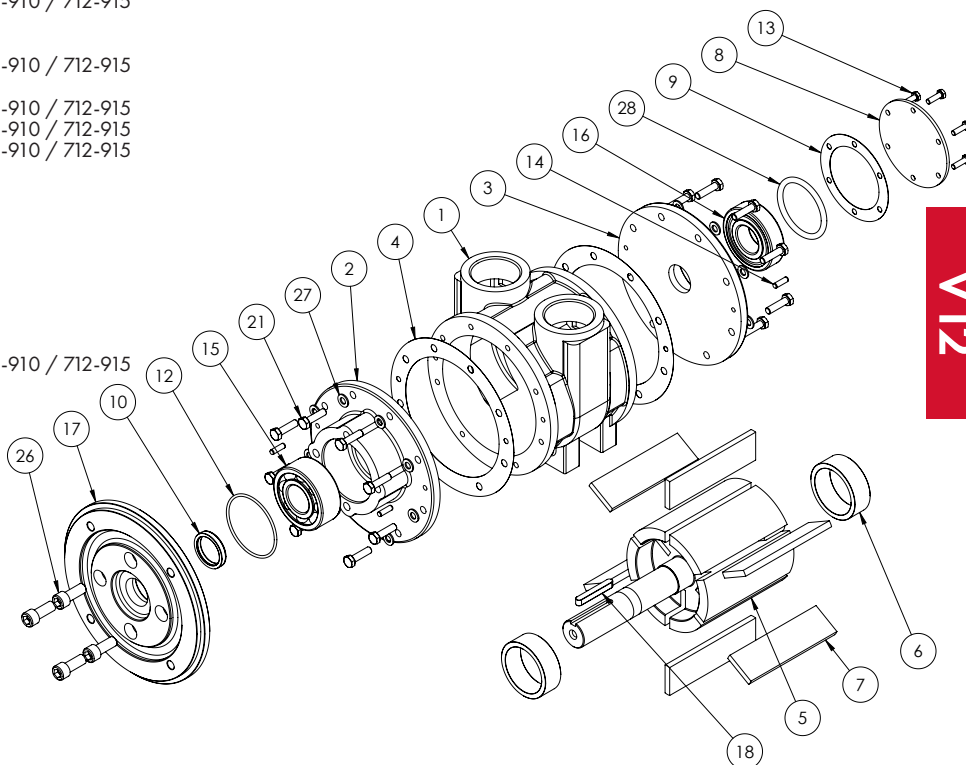

V12

Accessories

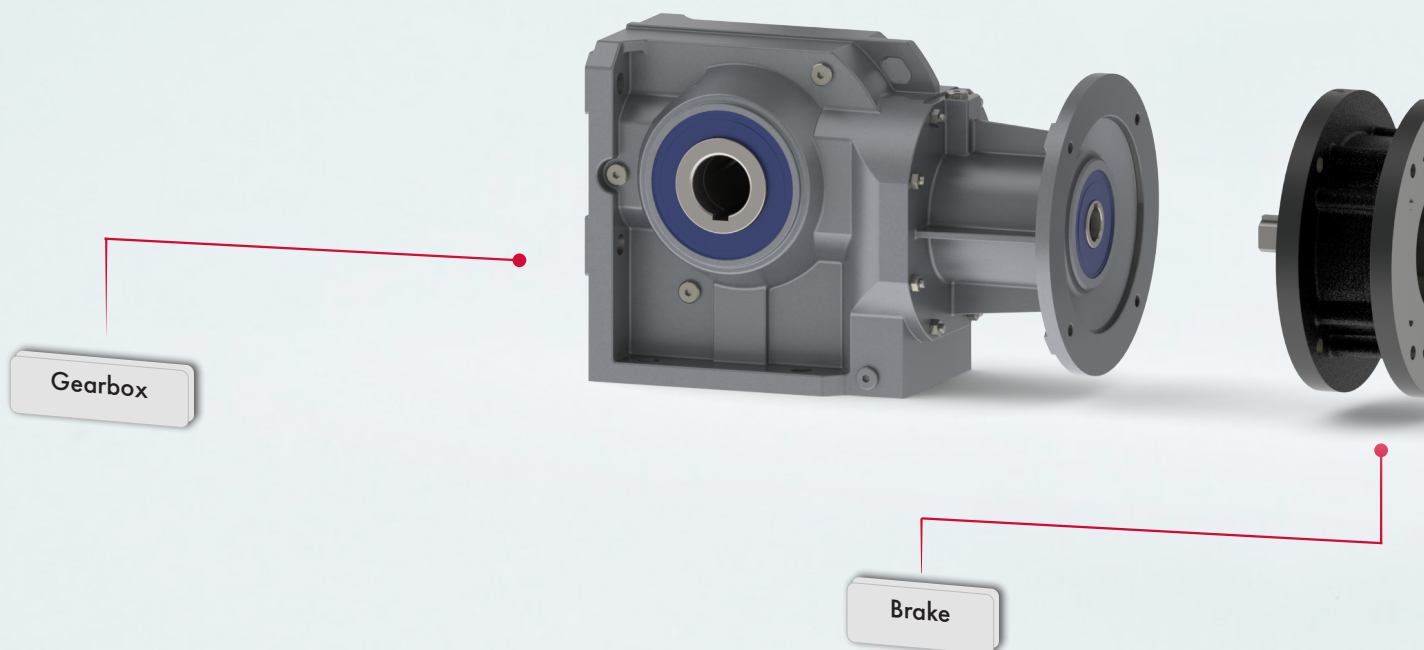
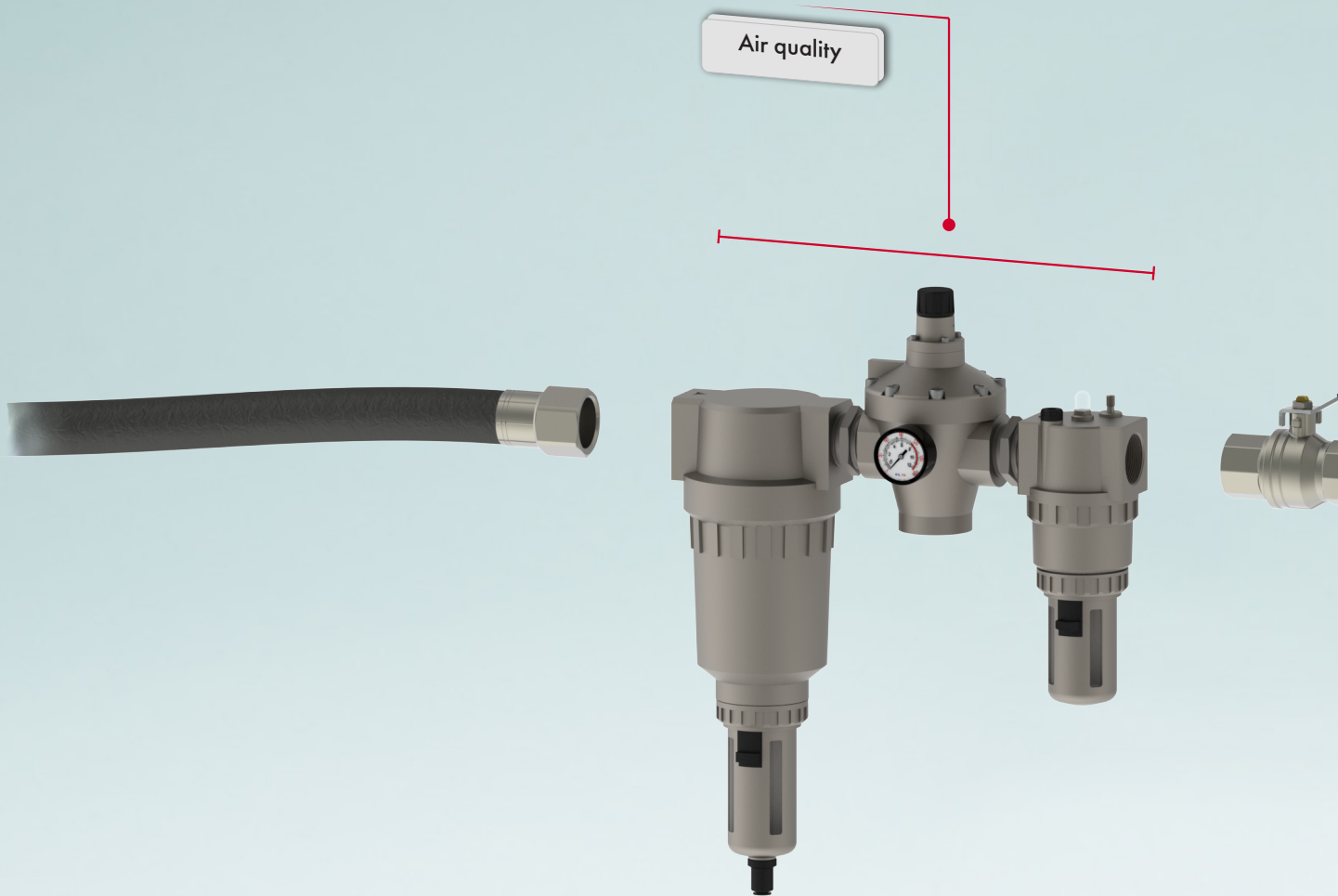

» Accessories for the GLOBE Vane Air Motor

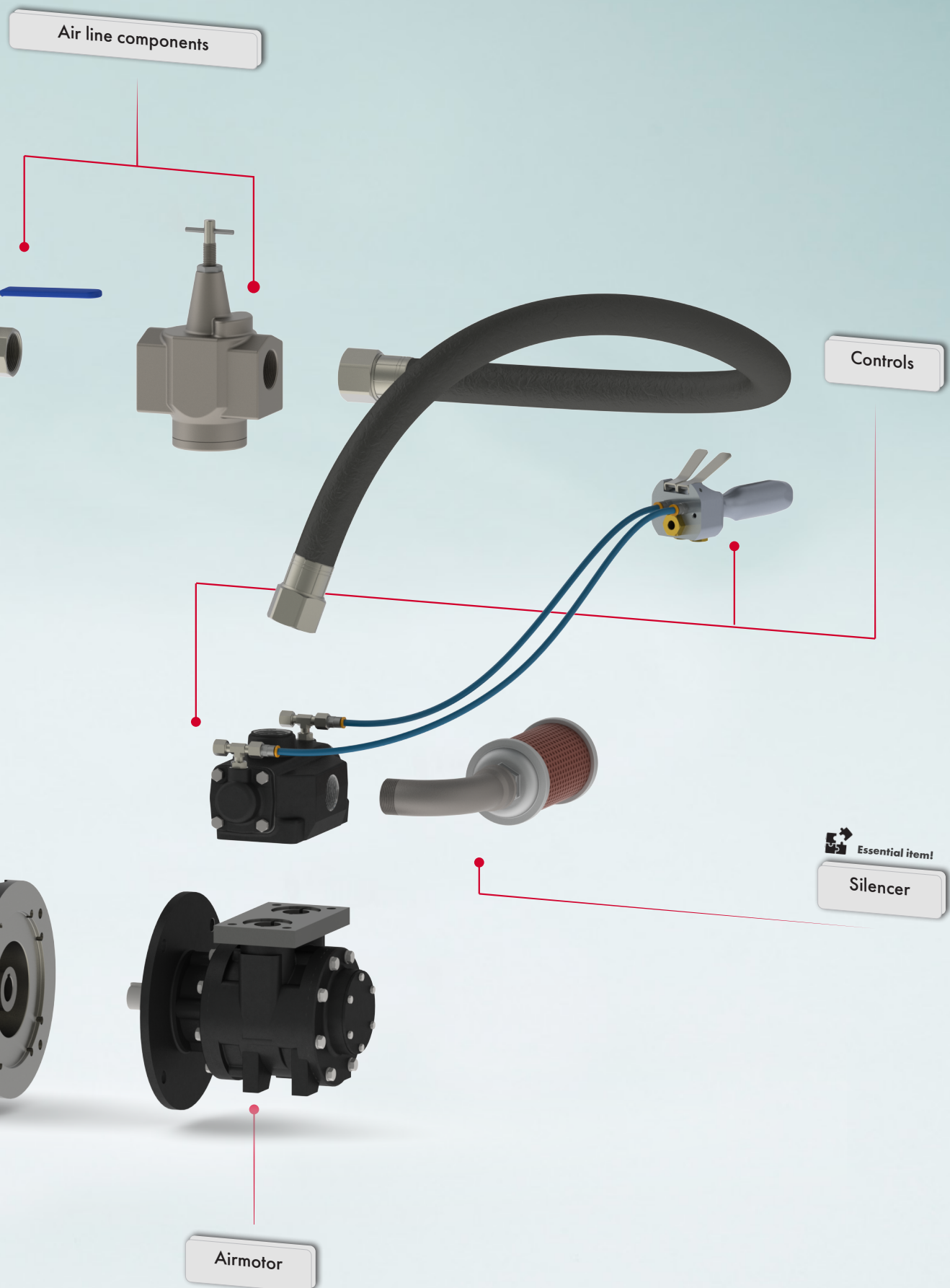

Gearboxes

Geared vane air motors

The GLOBE geared vane air motors are available with a standard range of worm and coaxial gearboxes. They generate high torques and low speeds of rotation which are required in many applications. Power ranges up to 13,5 kW at 6 bar air pressure. The motor and gearbox are directly mounted onto each other, making them compact and resistible against outside influences. GLOBE geared vane air motors are designed for smooth operation and are commonly used in mixing equipment, conveyor belts, hoists and winches, hose reels and turntables.

Advantages

GLOBE geared vane air motors have many advantages including:

- Power up to 13,5 kW/18.3 HP at 6 bar/90psi bar air pressure
- High nominal torques up to 1650Nm/1216 lbs.ft
- Speed of rotation as low as 7 rpm
- Easily variable and controllable speed and torque
- Perfect for applications in hazardous and aggressive environments
- ATEX certification on request
- No damage by overload or repeated starting
- Can be used in stall conditions
- Superior power to weight ratio
- Instantly reversible
- Minimum maintenance
- High radial and axial loads permitted
- Oil free possible

ATEX Certification possible

The GLOBE Gearboxes are delivered on request with ATEX.

The geared motors are marked with the following EX marking:

CE UK CA Ex II 2G Ex h IIC T4 Gb
II 2D Ex h IIIC T135°C Db
-20° ≤ Ta ≤ +60°C

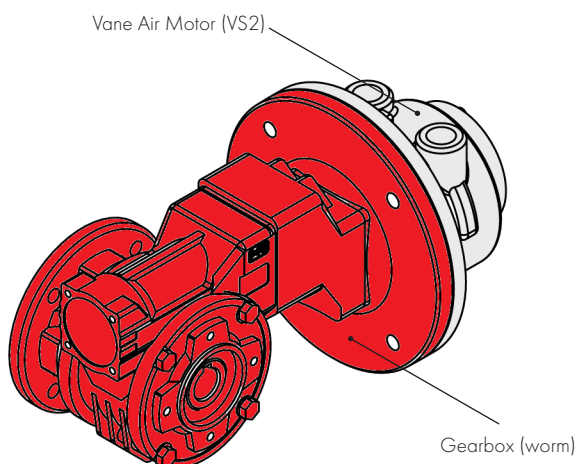

Features of the worm, coaxial and planetary gearboxes

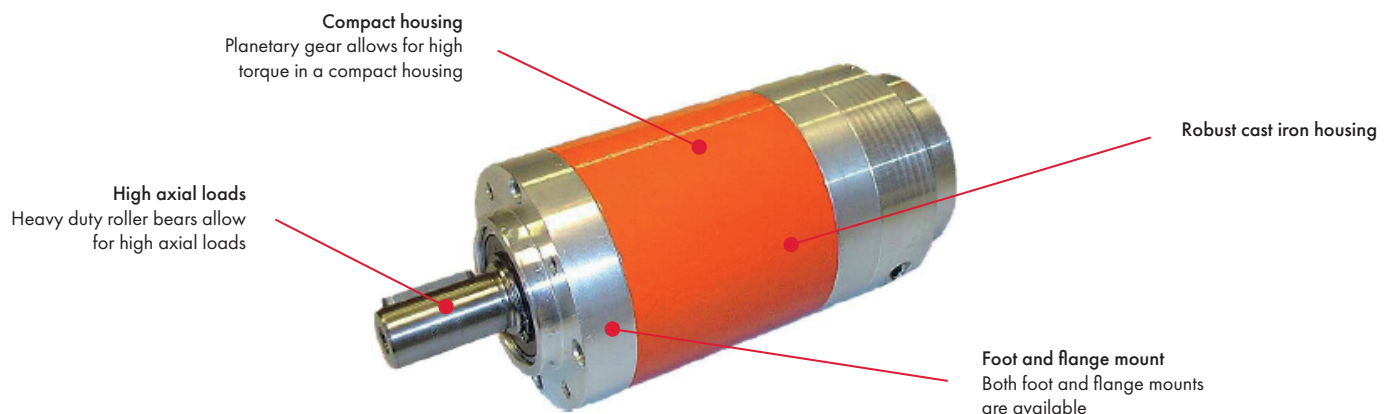
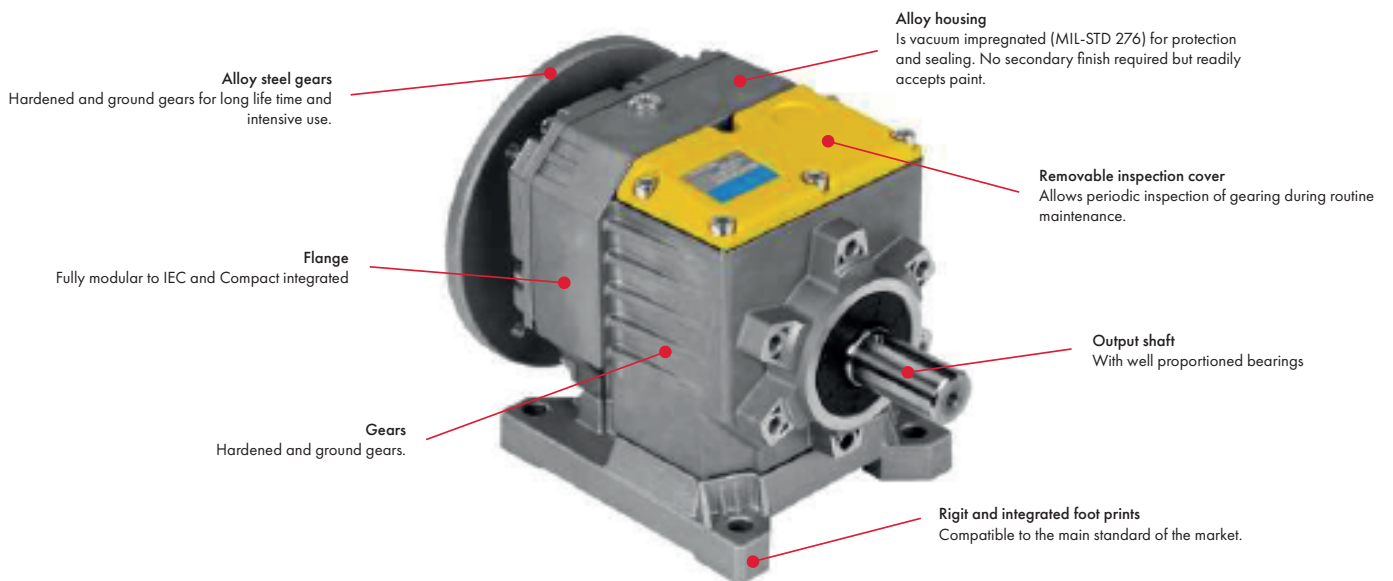
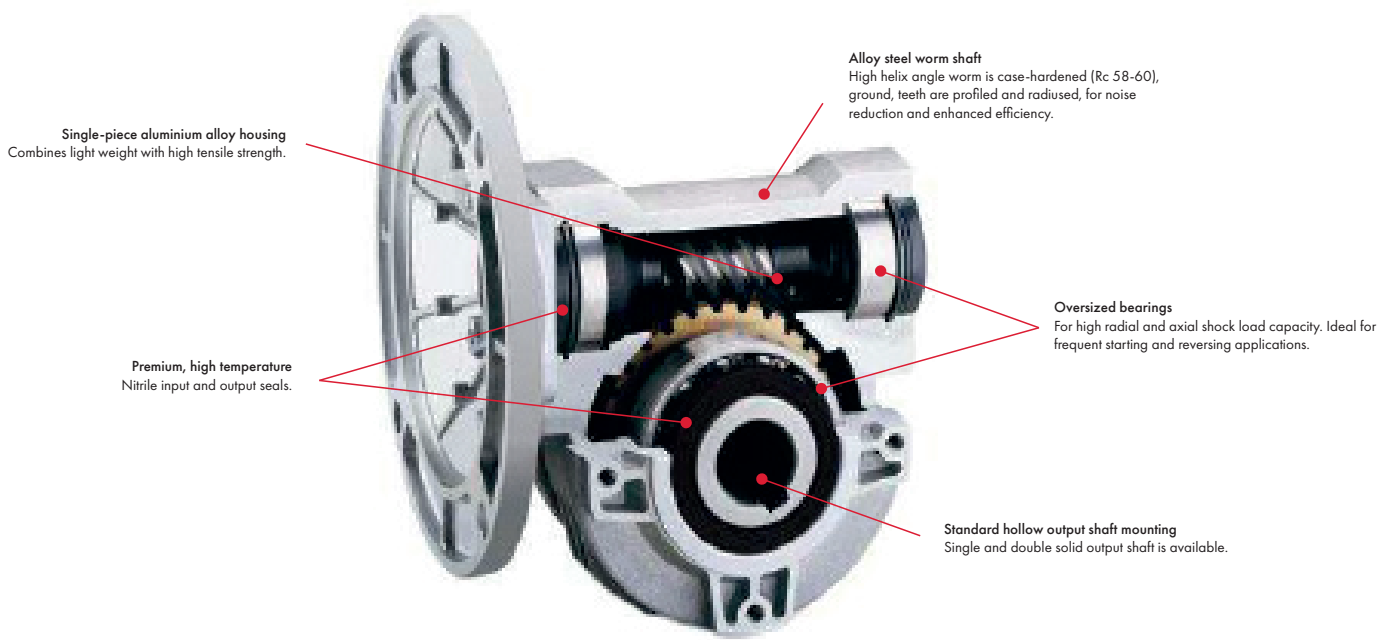

Brakes

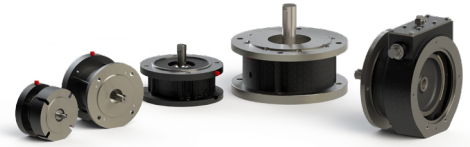

The GLOBE BN brakes are fail-safe brakes (spring engaged, air released) for our vane air motors. They can be used as a static brake. The brake module bolts directly onto the motor mounting face with an IEC connection flange. The brakes are certified according to ATEX (in static applications only).



Advantages

The advantages of the BN brakes include:

- » Brake can be used in dynamic applications;
- » Field serviceable;
- » Easy flange connection according to IEC and NEMA standards;
- » Low maintenance because very few parts are exposed to wear;
- » Compact design;
- » Easy interchangeable because of independent brake module;
- » Cast-iron housing and excellent thermal capacity for use in harsh environments;
- » Long service life;
- » Certified according to ATEX



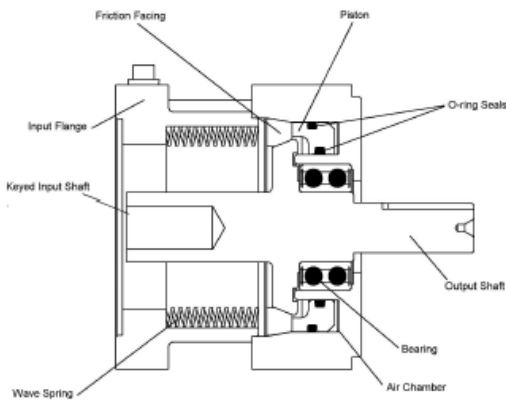

II 2G Ex h IIC T4 Gb
II 2D Ex h IIIC T135°C Db
 -20° ≤ Ta ≤ + 60°C

	BN71	BN90	BN100	BN300-4	BN300-6	BN300-8
Suitable for motor	V2; V4	V6; V8	V10	V12	V12	V12
Holding torque	14 Nm	29 Nm	75 Nm	300 Nm	450 Nm	600 Nm
Release pressure	3,4 bar	3,4 bar	3,4 bar	2,2 bar	3,2 bar	4,3 bar

Section drawings

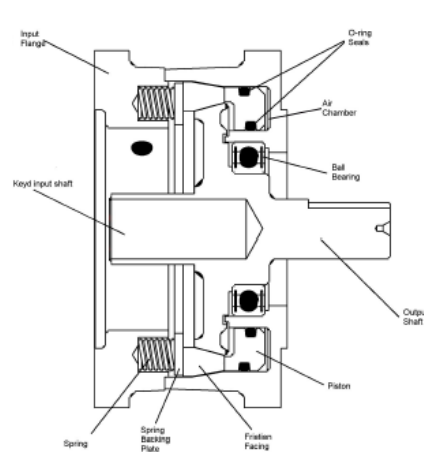

BN71 / BN90



BN100

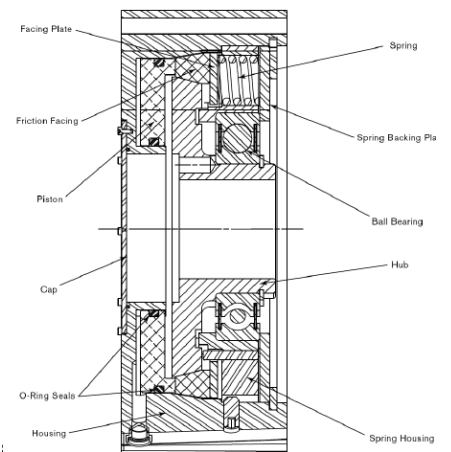

BN300
(without flanges and shaft)

Combinations

The combination of motor with brake is widely used for winches, cranes and positioning devices. All brakes are built from cast iron or steel housings and are available with either a IEC or NEMA flange mounting. This makes our brakes easy to install on our air motors and gearboxes. If you have special requirements, we are happy to advise you on compound combinations.

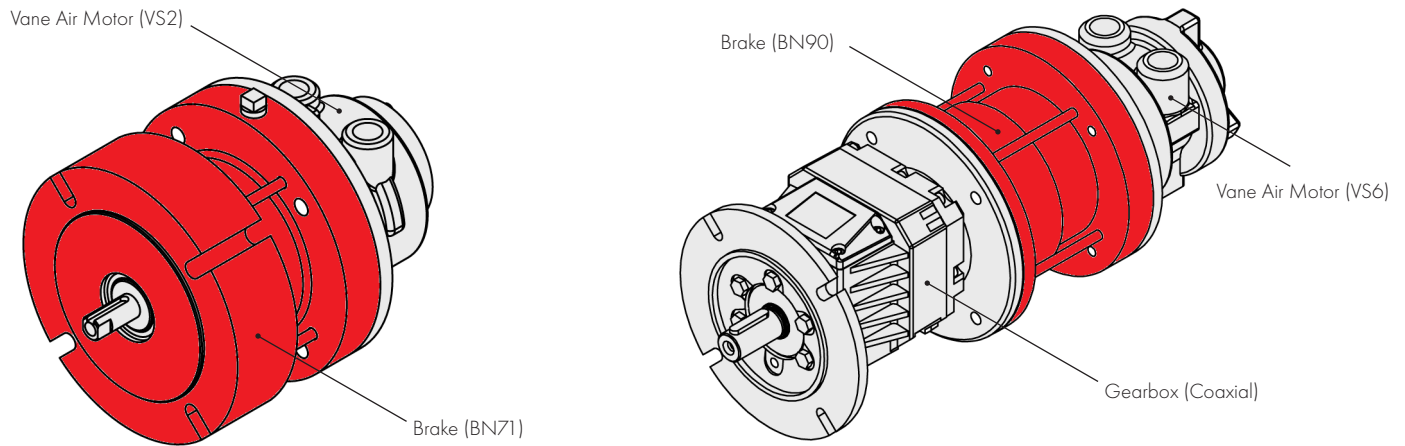

Controls

Control valves allow you to change the direction or the speed of the motor. We offer many different control valves for all our air motors. Proportional control valves are mounted directly onto the air motor and can control the direction and the (proportional) speed. Besides the proportional control valves we also offer standard control valves. You can choose between a hand control valve (HCV) or a remote control valve (RCV). Our vane air motors with RCV can be remotely controlled with a variety of pendant controls or lever controls.

Standard Control Valves

The advantages of the standard valves are:

- » Pre selected for use on GLOBE air motors;
- » Standard with ATEX for use in hazardous environments;
- » Easy to mount;
- » Valves have open centres in neutral position;



Proportional Control Valves

As standard the proportional valves can be supplied with either Equal Power or Biased Power spools, the latter is suitable for hoisting applications. The motor will have maximum power in lifting and reduced power in lowering. Because of the biased valve the load will not pull the motor in over speed in lowering direction. The direction of reduced power must be stated when ordering clockwise (CW) or counter clockwise (CCW) when viewed on the output shaft of the motor.

The advantages of the proportional valves are:

- » Robust cast steel body;
- » Standard with ATEX for use in hazardous environments;
- » High flow design for low back pressure;
- » Frictionless matched spool and sleeve;
- » Very accurate proportional control;
- » Available in equal power or reduced power



Hand Control Valves

The control valve spool is operated directly by a lever mechanism. Speed increase is obtained as the lever is moved in either direction from the central (neutral) position.

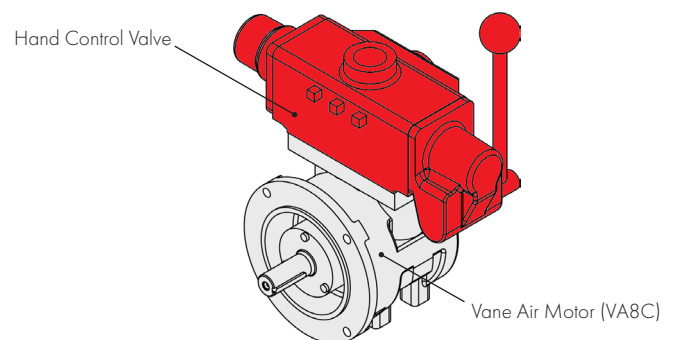
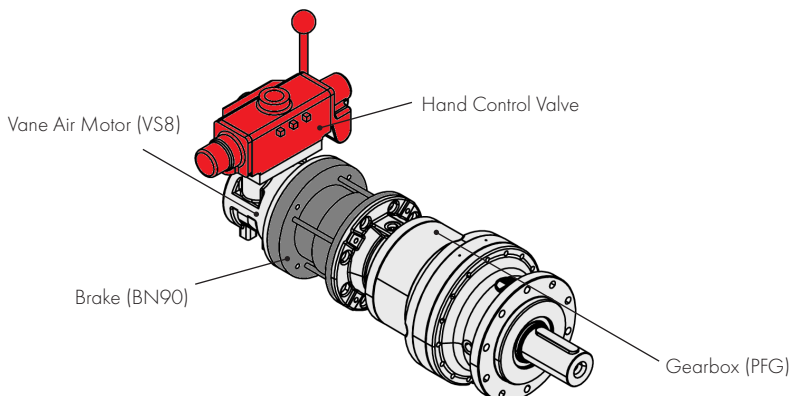

Remote Control Valves

This option is usually controlled from a remote position by one of the PC series or LC2 remote controllers. A variable air pilot signal is applied to either end of the valve spool, depending on the required direction of motor rotation. The pilot pressure range is between 1.4 bar (20 psi) and 4.8 bar (70 psi), increased pilot pressure gives increased speed. The valve is spring centred to neutral.

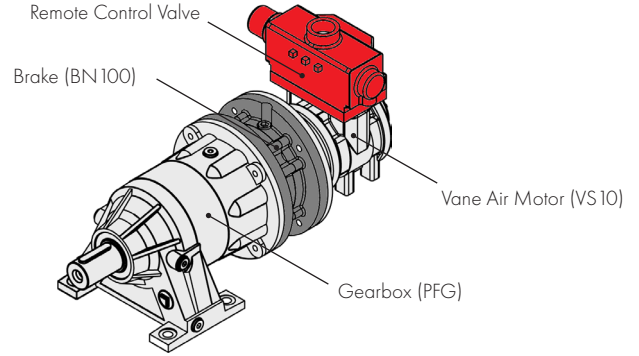
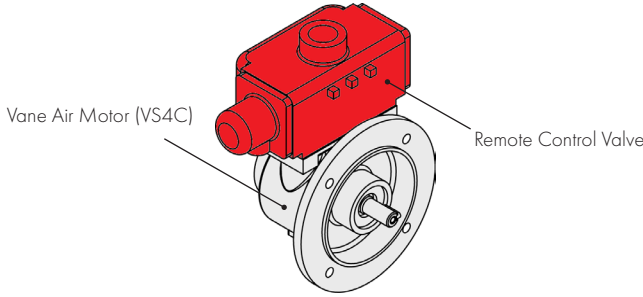

Pendant Controls (PC2, 4 or 6)

The PC2, 4 and 6 remote controllers are designed specifically for use with the RCV modules. They provide the correct range of pilot pressure required to operate the RCV units, and give excellent control of motor speed. The PC2 is used to control one (hoist) motor; the PC4 can control two motors independently (say hoist and long travel); the PC6 can control three motors independently (hoist, long travel, traverse). Motors of different sizes can be controlled from the same unit. Control line lengths of 36 m / 120 ft. give excellent response. For distance in excess of this contact factory. The control lines are small bore eliminating the need for large capacity air supply lines between motor and controller. If required, supply pressure can be taken from the tapping on the RCV. MARINE VERSION AVAILABLE. PC2M, PC4M OR PC6M.

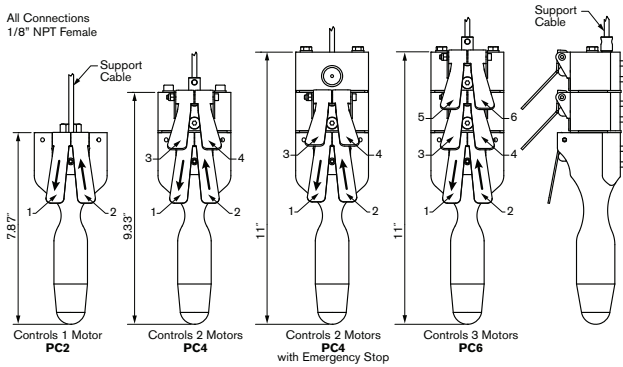

	PC2	PC4	PC6	PC4L	PC6L
KG	1.0	1.5	2.0	1.6	2.1
LBS.	2.3	3.3	4.3	3.5	4.7

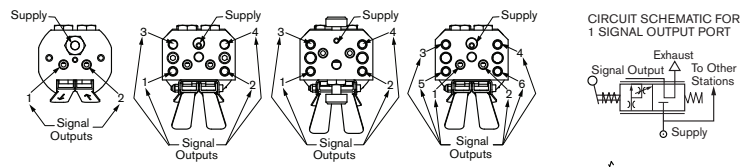

Lever control (LC2) / Marine Style (LC2M)

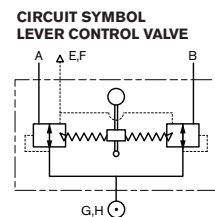
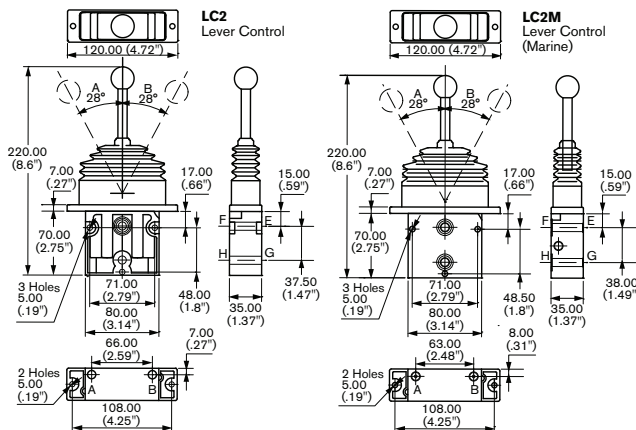

NOTE:
 H and G are alternative supply ports.
 A and B are outlet ports.
 Plug alternative ports not connected.
 E and F are exhaust ports.
 All ports are 1/8" (BSP).

Air quality

Air supply

To ensure optimal working conditions for the GLOBE Vane Air Motors, the air supply must be dry, filtered and lubricated. A 64 micron filters or better is recommended. The GLOBE Vane Air Motors should be lubricated sufficiently. A FRL system provides you with clean air and an efficient system that will extend the service life of air-powered tools and equipment.



Advantages

- » Pre selected for use on GLOBE air motors;
- » Possible with ATEX for use in hazardous environments (With Out of Scope Certificate);
- » The FRL units are ready to mount and supplied with a pressure gauge.

	GFRL 3/8"	GFRL 1/2"	GFRL 3/4"	GFRL 1"	GFRL 1 1/4"	GFRL 1 1/2"
Suitable for motor	V1; V2	V4	V6	V8	V10	V12
Port size	3/8"	1/2"	3/4"	1"	1 1/4"	1 1/2"
Max. operating pressure	10 bar					
Set pressure range	0,5 - 8,5 bar					
Ambient and fluid temperature	-5 to 60 °C					
Nominal filtration rating	5 µm					
Max. flow rate (L/ sec. free air)	25	50	75	165		200
Pressure drop (Δp) at 7 bar (105 psi) and max. flow rate	1 bar	1,2 bar	1,4 bar	1,5 bar		1,3 bar
Housing material	Aluminium					
Bowl material	Polycarbonate					
Weight (kg)	0,75	1,41	4,17	4,34		7,5
Recommended lubricant	Class 1 turbine oil (ISO VG32)					

Air line components

Speed regulators

Our speed regulation valves can be used in applications where you need to control the output speed of the air motor. The constant speed is easily set and can be controlled accurately. By using a speed control valve, you can set your air motor to a desired RPM without reducing its torque. It allows large airflows to pass while minimizing pressure loss at the same time.



Suitable for motor	V1; V2; V4	V6	V8	V10	V12
Port size	1/4"; 3/8"; 1/2"	3/4"	1"	1 1/4"	1 1/2"; 2"
Proof pressure	1.5MPa				
Min. operating pressure	1MPa				
Max. operating pressure	0.05MPa				
Ambient and fluid temperature	-5 to 60 °C (no freezing)				
Number of needle rotations	10 turns			12 turns	

Silencers

A pneumatic silencer is used to vent compressed air into the atmosphere. Depending on the flow and pressure of the air exiting the exhaust port of the air motor, it may produce noise that can be harmful to surrounding workers and/or cause noise problems in the application. In addition to noise, the exhaust air can also emit contaminants during operation. Filter elements in these silencers can prevent harmful contaminants from entering the environment.



Pneumatic air silencers, which can also be known as pneumatic mufflers, are a simple and cost-effective solution to reduce noise levels and unwanted discharge of contaminants. Silencers are an important part of all our air motors. They are not only there for noise damping, but also to ensure that the power of our air motors is maintained. Because of this we offer a broad range of silencers.

Mufflers screw directly into the primary and secondary exhaust ports. Note - control valves also have secondary exhaust ports. These mufflers are designed for intermittent use. For continuous operation contact factory.

We offer a standard range of silencers suitable for the different kind of air motors we produce. But special silencers are also an option. Please contact us for the possibilities.



A GLOBE Silencer is necessary for optimal reach of maximum power. Not installing a GLOBE Silencer will increase the risk of hearing damage, motor malfunctions or loss of power. It is also essential that an FRL unit is incorporated into the air-line to prevent motor malfunctions. Our silencers and FRL units are designed specifically for our motors to ensure maximum service life. Silencer supplied with motor.



GLOBE AIRMOTORS B.V.

GLOBE Airmotors | Boerhaaveweg 9-11 | NL - 2408 AD Alphen a/d Rijn | Tel +31 172 426 608 | info@globe-benelux.nl

Take a look at our other products

Wide range of products available



Compact Piston Air Motors

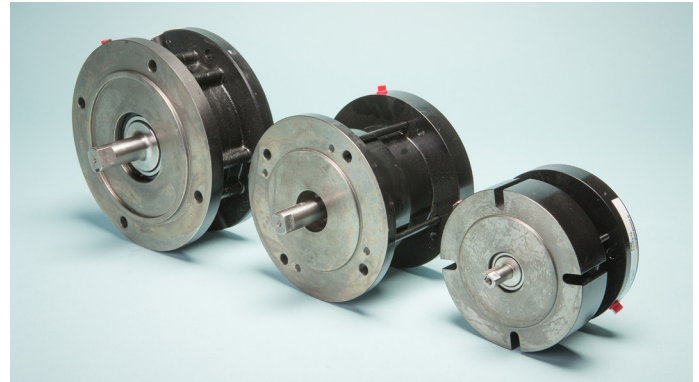

Pneumatic Brakes



Compact Vane Air Motors

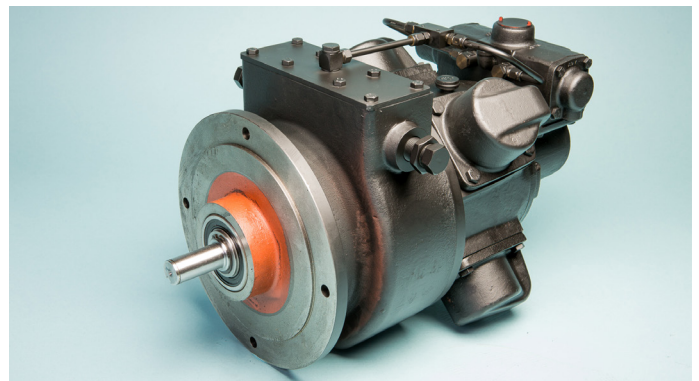



Piston Air Motors

This document, as well as the CAD data of the vane air motors are available for download on globe-airmotors.com.

Want to know more?

Please contact us.

 +31 172 426 608

 info@globe-benelux.nl

 [/company/globe-airmotorsentestequipment/](https://www.linkedin.com/company/globe-airmotorsentestequipment/)

www.globe-airmotors.com