



GLOBE PNEUMATIC BRAKES – BN SERIES

GLOBE BN brakes are fail-safe brakes (spring engaged, air released). They can be used as a static brake and under certain conditions in dynamic applications.

The brake module bolts directly onto the motor mounting face with an IEC or NEMA connection flange. The brakes are certified according to the European Explosive Directive ATEX II cat. 2 G&D T3 (in static applications only).

The advantages of the BN brakes include:

- Brake can be used in dynamic applications;
- Field serviceable;
- Easy flange connection according to IEC and NEMA standards;
- Low maintenance because very few parts are exposed to wear;
- Compact design;
- Easy interchangeable because of independent brake module;
- Cast-iron housing and excellent thermal capacity for use in harsh environments;
- Long life-time;
- Certified according to the European Explosive Directive ATEX II cat. 2 G&D T3.

GLOBE PNEUMATIC BRAKES - BN SERIES - IEC mounting

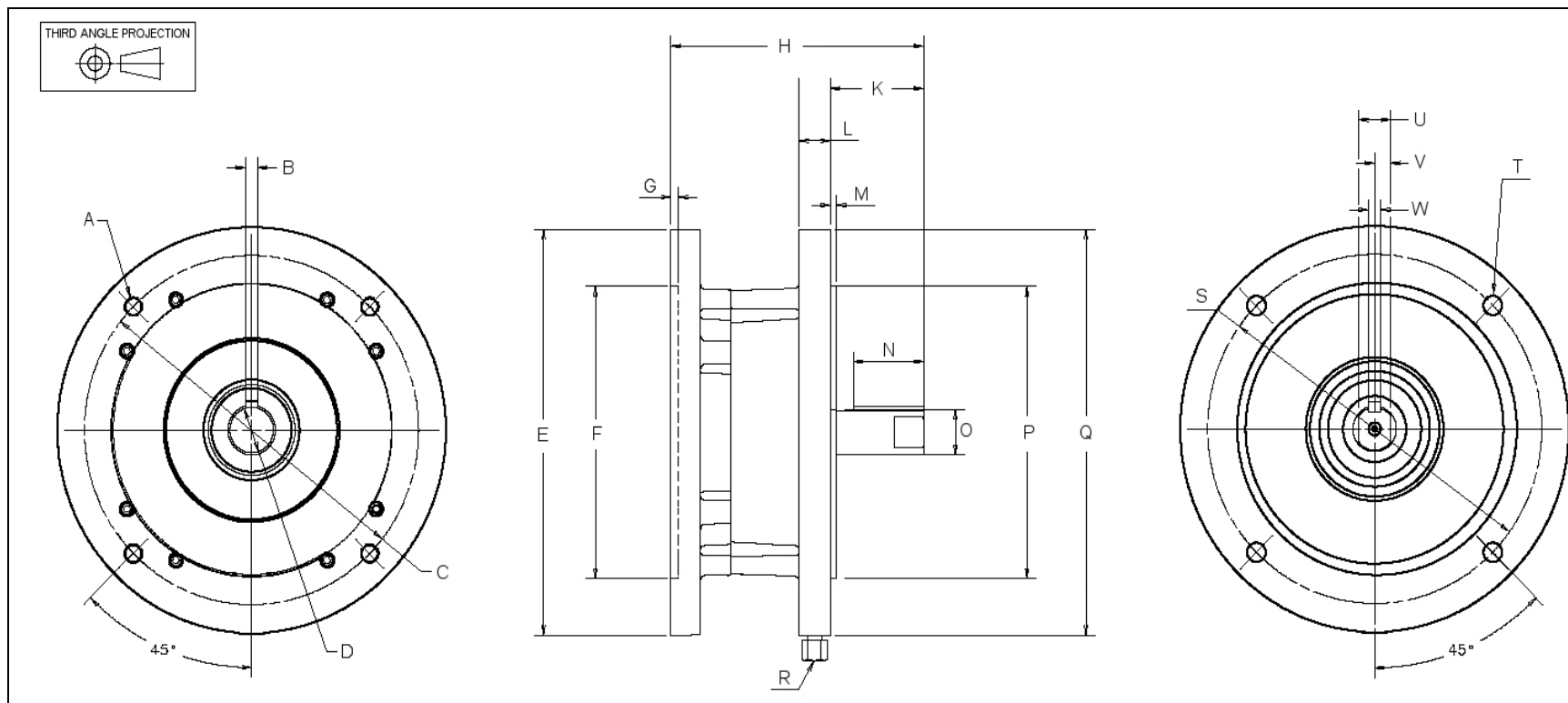

Brake type	A Ø	B	C Ø	D Ø	E Ø	F Ø	G	H	K	L	M	N	O Ø	P Ø	Q Ø	R	S Ø	T Ø	U	V	W
BN71	10	5	130	14H7	160	110H7	3,5	137	30	44.6	2,3	25	14h7	110h7	160	1/8NPT	130	10	11	5,5	5
BN90	M10	8	165	24H7	200	130H7	5	195	50	13	3,5	45	24h7	130h7	200	1/4BSP	165	12	18	9	8
BN100	M12	8	215	28H7	250	180H7	5	163	60	19	4	55	28	180	250	1/4BSP	215	14	20,6	10,3	8

Brake type	Flange type	Holding torque	Release pressure
BN71	IEC 71 (B5)	14 Nm	3,4 bar
BN90	IEC 90 (B5)	29 Nm	3,4 bar
BN100	IEC 100 (B5)	75 Nm	3,4 bar

Globe Airmotors B.V.
 Eikenlaan 261E
 2404 BP Alphen aan de Rijn
 Holland
 tel: (+31) 0172 – 426608
 fax: (+31) 0172 – 426607
 website: www.globe-benelux.nl
 e-mail: info@globe-benelux.nl



GLOBE PNEUMATIC BRAKES – BN SERIES

installation options

The brake releases with pneumatic pressure. When the pneumatic pressure drops below a pre-set air pressure the brake engages.

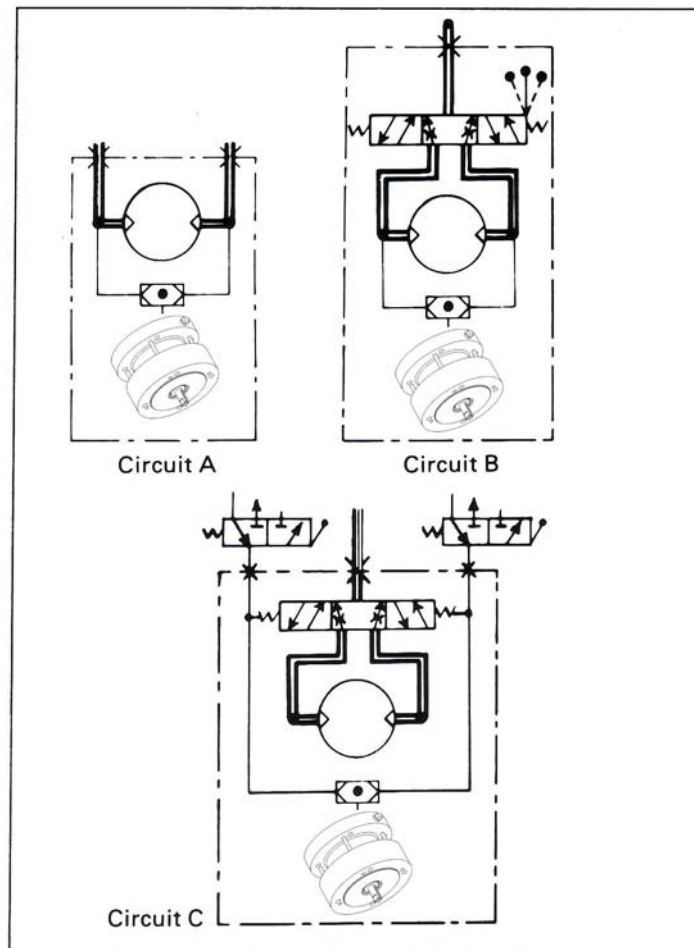

CIRCUIT (A): installation without control valve. The shuttle valve allows brake operation for dual rotation.

CIRCUIT (B): Installation with hand control valve (HCV). The HCV controls the rotation direction of the output shaft. The shuttle valve allows brake operation for dual rotation.

CIRCUIT (C): Installation with remote controlled valve (RCV). The RCV makes it possible to change the rotation direction of the shaft from a distance. The shuttle valve allows brake operation for dual rotation.

Section drawing GLOBE BN71 brake

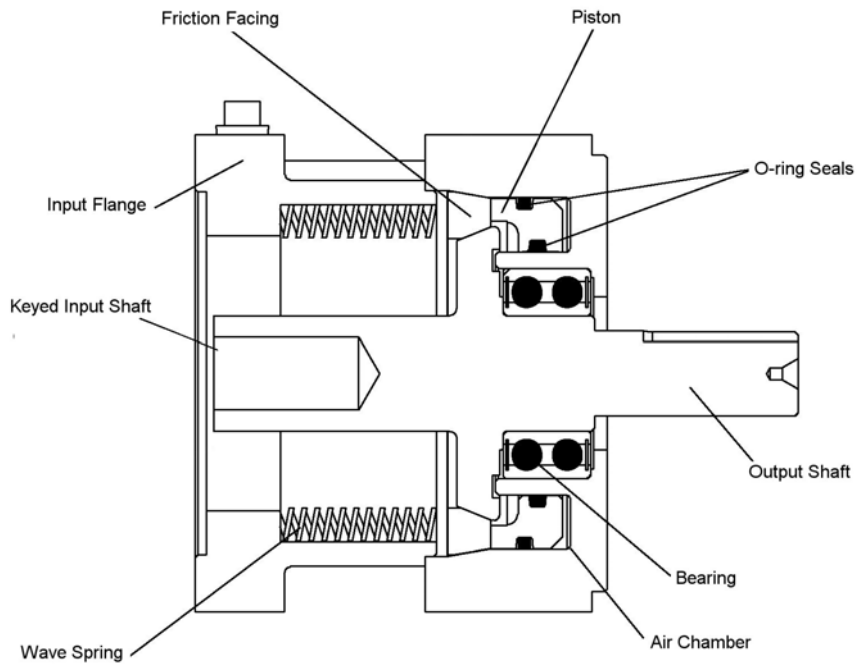

Section drawing GLOBE BN90 and BN100 brake

